



GENERAL INSTRUCTIONS AND FAQ'S

GENERAL INSTRUCTIONS

IMPORTANT: Please read these general instructions BEFORE REFILLING. It is also recommended that you read the quick start guide at:

http://freeink4life.com/support/Quick%20start_Guide_FI4L.pdf (Please click on link)

- 1) To avoid any potential spill or mess, refill your cartridge over a workbench or in an area that can tolerate a spill
- 2) Read the instructions for your specific cartridge first before attempting to refill
- 3) If you have any questions, ask our technical support for assistance first before making any attempt on your own (techsupport@freeink4life.com or call us at (559) 434-1000)
- 4) It is ALWAYS best to refill a cartridge when it is fresh – avoid as much as possible leaving cartridges sit empty for a long time as the print heads could clog. We include printer and head cleaner with some kits which can help to dissolve print head clogs. You can use this cleaner in the way explained in the instructions for your specific cartridge, and you could also pour a small amount of the cleaner into a cup and allow the print heads of the cartridge to sit in the cleaner for a few hours or overnight. DO NOT immerse any other parts of the cartridge in the cleaning solution, ONLY the print heads. Keep in mind that many cartridges (like Epson, Canon) do NOT have print heads – so this procedure does not apply. In general, you should try refilling cartridges when they are running low or when they have freshly emptied.
- 5) Try avoiding over-filling any cartridge. It is always better to under-fill rather than over-fill, as you can always fill again later. Refill slowly to avoid overfilling and creating any potential spill.
- 6) Be very careful to insert the correct color ink into the correct chamber. If you are unsure, you can usually check by inserting a toothpick into the filling chamber to see what color ink was there before. Refer to the diagrams in the instructions, or email technical support for assistance if you need to. REMEMBER:

- BK = K = Black
- C = Cyan (which is blue)
- M = Magenta (which is red)
- Y = Yellow (which is yellow)
- PC = Photo Cyan (or light Cyan)
- PM = Photo Magenta (or light Magenta)

7) If you have quality problems such as faded prints or skipping lines, try soaking the cartridge heads a little in the print head cleaning solution or dabbing the print heads on a soft paper towel that has been moistened with water or print head cleaning solution. You need to get the ink to FLOW through the heads, so by dabbing on the paper towel you are creating a wicking effect that drains the ink to the bottom and out of the heads. For other troubleshooting advice, please email your specific problem to techsupport@freeink4life.com or call us at (559) 434-1000. Over 90% of problems related to quality can be solved!

FAQ'S

(1) Does using Freeink4life ink or toner refills damage my printer?

As regards your printer warranty, please read the Magnuson-Moss Warranty Improvement Act United States Code Annotated Title 15 Commerce and Trade Chapter 50 Consumer Product Warranties 15 Section 2302:

No warrantor of a consumer product may condition his written or implied warranty of such product on the consumer's using, in connection with such product, any article or service (other than article or service provided without charge under the terms of the warranty) which is identified by brand, trade or corporate name; except that the prohibition of this subsection may be waived by the commission if: 1. The warrantor satisfies the Commission that the warranted product will function properly only if the article or service so identified is used in connection with the warranted product, and 2. the Commission finds that such a waiver is in the public interest.

What this means to you: The manufacturer of the printer you are using cannot void the warranty on your printer because you use a cartridge or refill kit manufactured by someone other than the printer manufacturer.

(2) Will using Freeink4life ink refills clog my printer heads?

For inkjet cartridges: Print heads may become clogged if the cartridge is left empty for an excessive period of time. It is always best to refill before the cartridge empties or soon after it empties. Clogged print heads can be unclogged most of the time by soaking the cartridge print heads in our "cartridge and print head cleaner" solution for a few hours. As long as you refill your cartridge soon after it empties (preferably even before it is completely empty), you will minimize the risk of clogged print heads.

(3) How many refills will I get from 1 kit?

This depends on the cartridges you have. With the Freeink4life Inkjet Refill Kit you can refill most black and color inkjet cartridges approximately 10 times each.

(4) Is the refill process messy? Is it safe?

The Freeink4life refill kits are not messy if used carefully. The inkjet kit uses an injector system that allows you to accurately control the filling. Also use the refilling cradles and refill in the front cover of the box work station.

The ink is not harmful unless ingested, so keep it out of reach of younger children and avoid contact with eyes. Wash affected areas with water, and if ingested or ill effects develop, call medical aid.

(5) Will the Freeink4life work with my specific printer?

Yes, if you have an inkjet printer it can be refilled with the Freeink4life Inkjet Refill System. This is because all inkjet cartridges have a filling hole which can be exposed and used to refill that cartridge with more ink. The Freeink4life has a specially designed ink that works in ALL inkjet printers. Our instructions are updated regularly; if your printer or cartridge is not listed in the instruction manual please email tech support: techsupport@freeink4life.com or call us at (559) 434-1000. Some printers or cartridges have "lockout" mechanisms that prevent the cartridge from being recognized after it is refilled. **Want to make refilling even easier?** New empty refillable cartridges are your solution! Empty refillable cartridges are sold separately with auto reset chips on them. Note: Some printers will STILL PRINT even though they give an error message, you can ignore the error message and continue printing. For Epson cartridges, these require that their chips be reset; an Epson Resetter is sold separately.



INDEX

Brother Cartridges

IN-700, LC11BK _____	1
IN-710C, LC11CL _____	1
LC03BC, LC03MY _____	2
LC01BK, LC01C, LC01M, LC01Y _____	3
LC02BK, LC02C, LC02M, LC02Y, LC21Bk, LC21C, LC21M, LC21Y, LC31C, LC31M, LC31Y, LC31BK _____	4
LC04C, LC04M, LC04Y, LC04BK _____	5
LC41C, LC41M, LC41Y, LC41BK _____	6
LC25Bk, LC25C, LC25M, LC25Y _____	6
LC51 _____	7
LC61BK, LC61C, LC61Y, LC61M, LC65BK, LC65C, LC65Y, LC65M _____	8

Canon Cartridges

BCI-21 & 24 _____	9
BC-20 & BC-23 _____	10
BJI-201BK HC, BJI-201BK, BJI-201C, BJI-201M, BJI-201Y _____	11
BC-01, BC-02, BC-05, BX-02, BX-03, BC-06 _____	12
BCI-60, BCI-61, BCI-62 _____	13
BCI-3eBk, BCI-3eC, BCI-3eM, BCI-3eY, BCI-3Bk, BCI-3C, BCI-3M, BCI-3Y, BCI-3PBk, BCI-3PC, BCI-3PM, BCI-5Bk, BCI-5C, BCI-5M, BCI-5Y, BCI-5PC, BCI-5PM, BCI-8Bk, BCI-8C, BCI-8M, BCI-8Y, BCI-8PBk, BCI-8PC, BCI-8PM, CLI-8, PGI-5, PGI-220, CLI-221 _____	14
BC-22e _____	15
PG-40, PG-50, CL-41, CL-51, CL-52, PG-210, CL-211 _____	16

Compaq Cartridges

337714-001, 180845-001, 337709-001, 180847-001, 337715-001, 180846-001, 337710-001, 180848-001, 180844-001, 337711-001_	17
----------------------------------------------------------------------------------------------------------------------------	----

Dell Cartridges

7Y743, T0529, T0601 _____	18
7Y745, T0530, T0602 _____	18
MK990, MK991, MK992, MK993, Series 7, Series 8, Series 9, Se- ries 11, Series 15 _____	38

Digital Cartridges

LJ50X-AB, LJ50X-AK, LJ50X-AC _____	19
------------------------------------	----

Epson Cartridges

S020062, S020118, S020122, S020130 _____	20
S020093, S020097, S020110, S020193, S020187, S020189, S020191, S020089, S020093, S020108, S020047, S020049, S020097, S020034, S020036, S020138, T007201, T008, T008201, T009, T009201, T013, T014, T015201, T016201, T017, T018, T019201, T020201, T026, T027, T028, T029, T036120, T037020, T040120, T041020 _____	21
T0321, T0322, T0323, T0324, T0331, T0332, T0333, T0334, T0335, T0336, T0341, T0342, T0343, T0344, T0345, T0346, T0347, T0348, T0422, T0423, T0424,	



INDEX

Epson Cartridges

ICD Y21	22
T0431, T0441, T0442, T0443, T0444, T0481, T0482, T0483, T0484, T0485, T0486, T0540, T0541, T0542, T0543, T0544, T0545, T0546, T0547, T0548, T0549, T0601-T0604	23

Hewlett Packard Cartridges

51626A, 51629A, 51626G, 51629G, 51633M, C6614AN, C6628AN	24
51625A, 51649A, 51649G, C1816A	25
51645A, 51645G, 51640A, 51640C, 51640M, 51640Y, 51644C, 51644M, 51644Y, C6615DN, C6615AN	26
51641A, C1823A, C1823D, C1823G, C6625AN, C6578AN, C6578DN, C3844A, C3845A	27
C4841A, C4842A, C4843A, C4844A, 38, 50, 70, 72, 82, 84, 85, 88, 940	28
21, 22, 27, 28, 56, 57, 58, 60 (Black and Color), 74, 74XL, 75, 75XL, 92, 93, 94, 95, 97, 98, 99, 110, 901 (Black and Color)	29
564, 920 Cartridges	30
C1806A, C1807A, C1808A, C1809A	31
C5010A, C5011A	32
C6634A, C6635A	33
C8721, C8771, C8772, C8773, C8774, C8775 (HP 02) Cartridges	34

Lexmark Cartridges

10N0016, 10N0217, 12A1970, 12A1975, 1361400, 13400HC, 1380620, 1382050, 15M2971, 16G0055, 17G0050, 18L0032,	35
12A1980, 12A1985, 1380619, 10N0026, 15M0120, 15M0125, 18L0042, 1382060, 17G0060, 16G0065	35
12A1990, 1361760	35
1380490, 1380491, 1380492, 1380493	36
18C0031, 18C0032, 18C0033, 18C0034, 18C0035	37
#1, #2, #3, #4A, #5A, #14A, #15A, #23A, #24A, #28A, #29A, #32, #33, #34, #35, #36A, #37A, #41A, #42A, #43, #44,	38
100A	39

Okidata Cartridges

52109301	40
52109302	40
52110001, 52110002, 52110003, 52110004	41

Pitney Bowes Cartridge

769-0	42
793-5	50
797-0	51
765-0	52



INDEX

Sharp Cartridges

AJ-C50B, UX-C70B	42
AJ-C50C	42

Xerox Cartridges

8R12591, 8R7880, 8R882	43
8R7881	43
8R7660, 8R7661, 8R7662, 8R7663	44
8R7638	45
8R7903, 8R7904	46
8R12728	47
8R7971, 8R7972, 8R7973, 8R7974	48

Brother Cartridges

Black Cartridges: IN-700, LC11BK

1. Use the enclosed eyelet screw to enlarge the filling hole located at the top of the cartridge. (Do not remove the cap.)
2. Connect the needle to the syringe and fill the syringe with 8 ml. of Cartridge & Print Head Cleaner and inject into the cartridge. Reinsert cartridge into printer and print 5 test pages.
3. Fill the syringe with ink. Insert the needle into the filling hole and push down into the cartridge. Inject up to 20 ml. of ink or until the cartridge is full.

Note: Immediately refill any empty cartridges.

Color Cartridges: IN-710C, LC11CL

1. The filling holes are located under the plastic cap. Use a thin flathead screwdriver or knife to remove the cap. **Important: Do not damage the sensors on the back of the cartridge.**
2. Connect the needle to the syringe and fill with ink.
3. Insert the needle into the matching hole of the color to be refilled, (see diagram above) and push into the cartridge. **Note: You will feel a slight pressure because the cartridge contains a sponge.**
4. Inject about 8 ml. of ink, per color, into the cartridge until the ink begins to bubble at the top of the sponge. **Important: Do not overfill. Keep the sponge inside the cartridge white.**
5. Rinse the needle and syringe with water and dry between each color refilling or store for future use.
6. The cover can be reattached with a piece of tape.

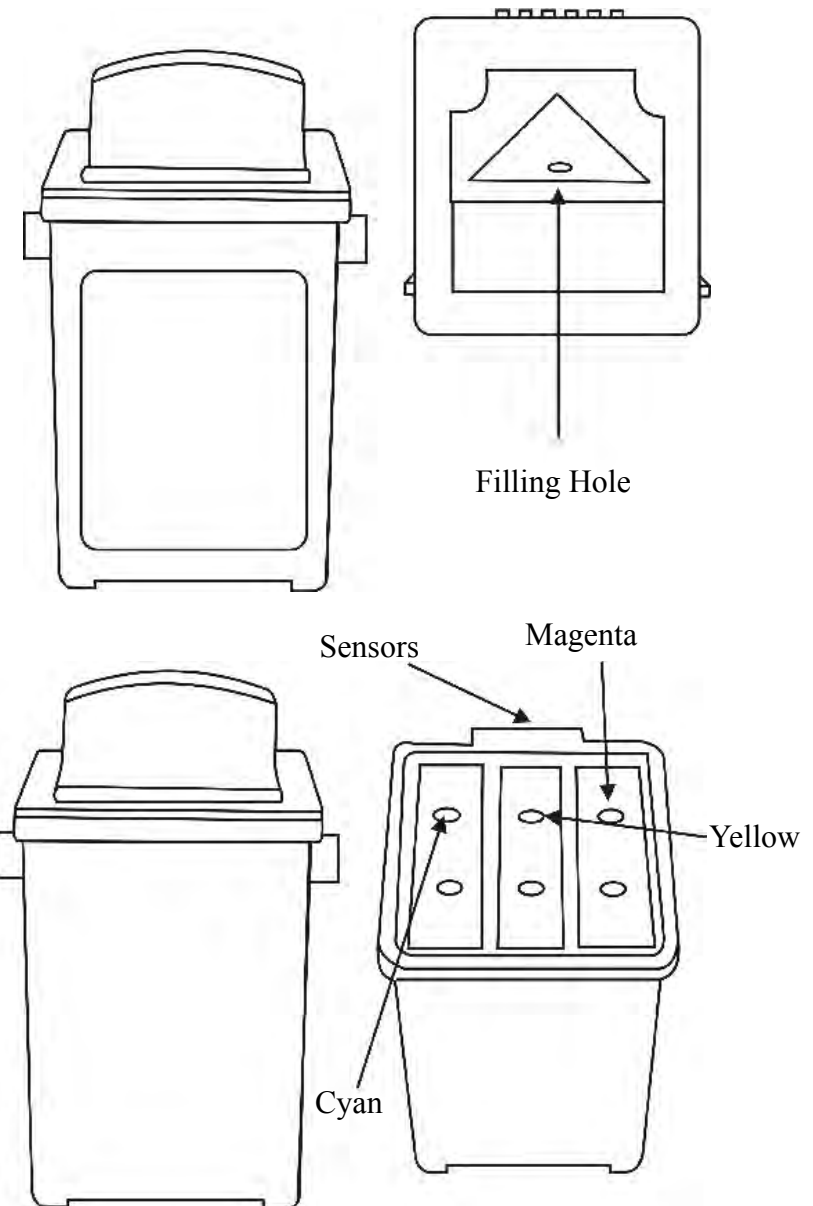

Brother Cartridges

LC03BC, LC03MY

1. The filling hole is the same hole as the hole that connects to the printer.
2. Note: The cartridge is lined in a delicate Mylar bag and it is very important not to insert the needle more than 3/4" or it is possible to pierce or tear the Mylar bag. **Important: It is very important to turn the cartridge as shown in the pictures. If you have the cartridge reversed then you will put the wrong color of ink in the wrong fill hole.** Fill the syringe with ink and carefully insert the needle into the filling hole and slowly inject about 4 ml. of ink into the cartridge.
- 3 Hold the cartridge up with the filling hole at the top. Using the syringe, remove any trapped air in the cartridge by only inserting the tip of the needle and pulling up on the plunger until all air is removed.
4. Remove the syringe and rinse with water and dry for future use, or to use with a different color ink.
5. Reinsert the cartridge and run a priming cycle as per printer instructions.

NOTE: It is not necessary to disassemble the cartridge to refill it and we strongly recommend you do not.

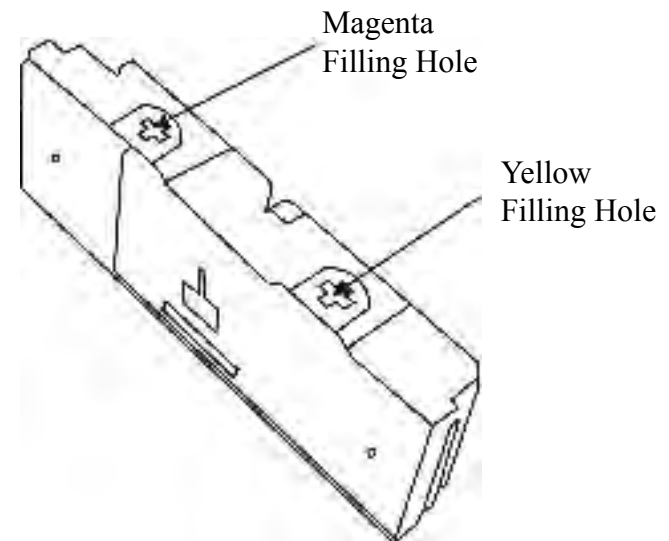
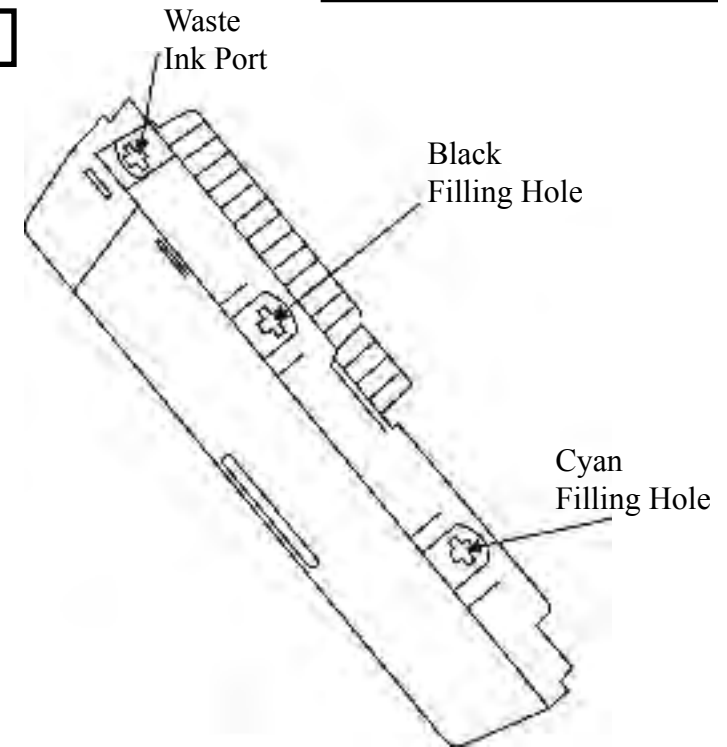

Brother Cartridges

LC01BK, LC01C, LC01M, LC01Y

1. The filling hole is located under the label as shown. Just peel back the label leaving it still connected to the cartridge, do not remove completely.
2. Use the provided eyelet screw to drill a filling hole on the top of the cartridge(s) into the lower area.
3. Connect the needle to the syringe and fill with ink.
4. Insert the needle into the filling hole and inject about 10ml of ink.
5. Pull the label back into place and use a piece of tape to hold it in place.
6. Rinse the syringe with water and dry between each color refill or store for future use.
7. Reinsert cartridge back into the printer and run 1 - 3 cleaning cycles as per printer instructions.

Filling Hole

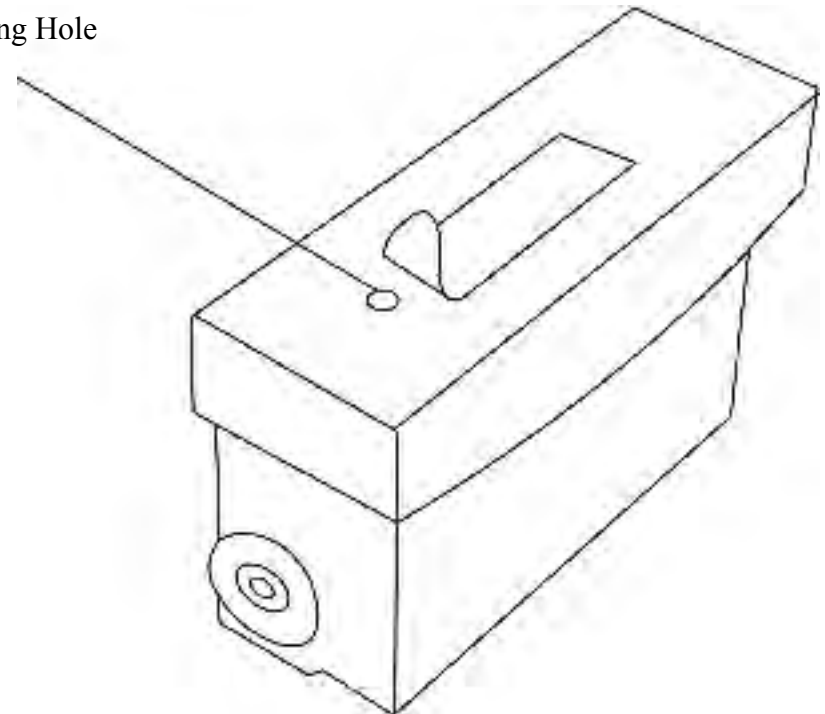

Brother Cartridges

LC02BK, LC02C, LC02M, LC02Y, LC21Bk, LC21C, LC21M, LC21Y, LC31C, LC31M, LC31Y, LC31BK

1. Put a piece of tape over the bottom hole of the cartridge.
2. Use a flathead screwdriver to remove the cover by prying up the clip holding the cover on the cartridge.
3. Using a knife remove both the small and large silver seals.
4. Underneath the large silver seal there are two holes (filling hole and vent hole), use the eyelet screw to widen the hole closest to the center of the cartridge (not the hole closest to the edge of the cartridge) Also widen the small hole located under the small silver seal.
5. Connect the needle to the syringe and fill ink.
6. Insert the syringe into the hole that was located under the large silver seal. **Note: You may feel a slight pressure because the cartridge contains a sponge.**
7. Inject about 7 ml. of ink and reseal the filling hole and vent hole with a piece of tape.
8. Insert the syringe into the small filling hole no more than 1/4" and inject approximately 3 ml. of ink and seal with a piece of tape.
9. Snap the plastic cover back onto the cartridge the same direction it came off.
10. Rinse the syringe with water and dry between each color refill or store for future use.
11. Remove the tape covering the bottom hole and reinsert the cartridge(s) and run a priming cycle as per printer instructions.

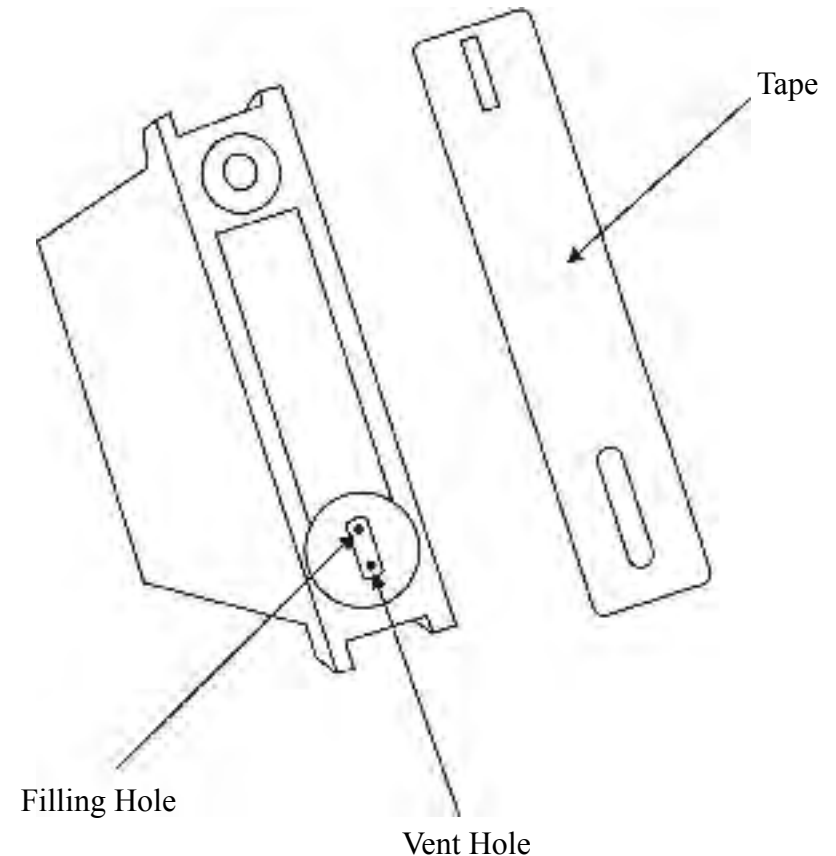

Note: Immediately refill any empty cartridge

Brother Cartridges

LC04C, LC04M, LC04Y, LC04BK

1. Put a piece of tape over the bottom hole of the cartridge.
2. Use a flathead screwdriver to remove the cover by prying up the clip holding the cover on the cartridge.
3. Using a knife remove the large silver seal.
4. Underneath the large silver seal there are two holes (filling hole and vent hole), use the eyelet screw to widen the hole closest to the center of the cartridge (not the hole closest to the edge of the cartridge)
5. Connect the needle to the syringe and fill ink.
6. Insert the syringe into the hole that was located under the large silver seal. **Note: You may feel a slight pressure because the cartridge contains a sponge.**
7. Inject about 7 ml. of ink and seal the filling hole and vent hole with a piece of tape.
8. Snap the plastic cover back onto the cartridge the same direction it came off.
9. Rinse the syringe with water and dry between each color refill or store for future use.
10. Remove the tape covering the bottom hole and reinsert the cartridge(s) and run a priming cycle as per printer instructions.

Note: Immediately refill any empty cartridge

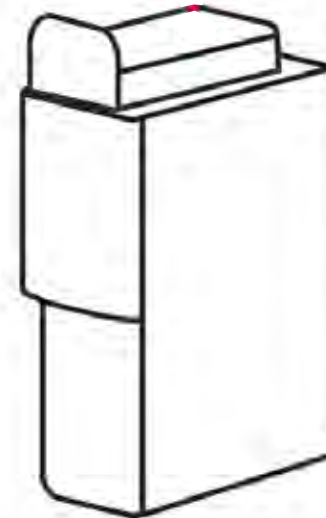

Filling Hole

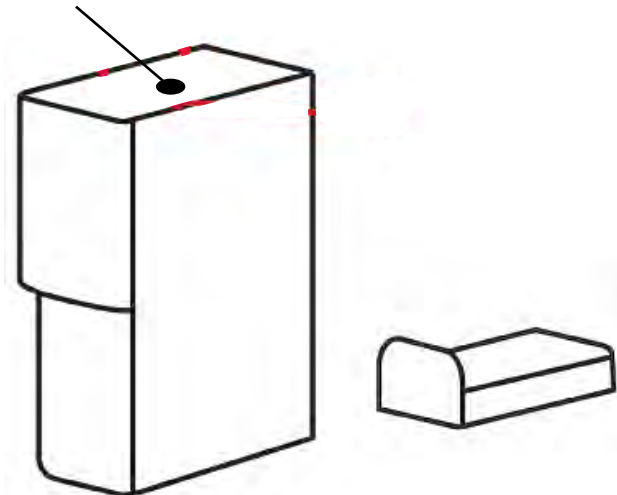

Brother Cartridges

LC41C, LC41M, LC41Y, LC41BK

1. Stand the cartridge on a towel or ink spillable table. Using the eyelet screw provided, begin twisting the screw into the front of the cartridge (see illustration to the right). Continue twisting until it pierces the plastic..
2. Connect the needle to the syringe and fill with ink.
3. Insert the syringe into the hole and inject about 20 ml. of ink
4. Seal the filling hole with one of the included tape dots or a piece of duct tape.
5. Rinse the syringe with water and dry between each color refill or store for future use.

Crear Refill Hole

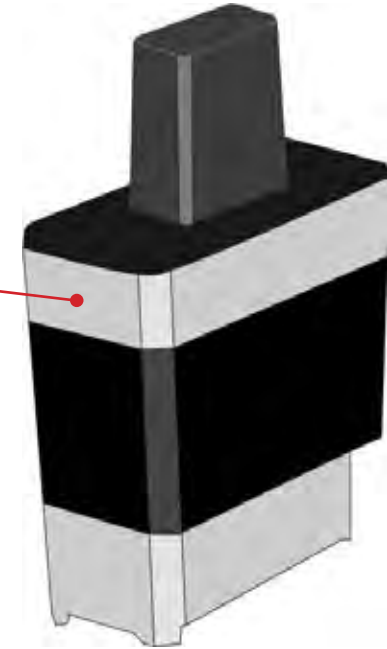

LC25Bk, LC25C, LC25M, LC25Y

1. Use the eyelet screw to remove the white plug located next to the exit hole. The plug does not need to be removed completely since the white plug and the exit hole plug are connected.
2. Connect the needle to the syringe and fill with ink.
3. Insert the syringe through the filling hole which is found where the white plug was removed.
4. Inject up to 8 ml. of ink (this cartridge is transparent so you will see the ink level) then reseal the cartridge with the plug that was removed from step 1. Make sure that the small plastic tip of the plug sits back into the filling hole.
5. Rinse the syringe with water and dry for future use, or use with a different color ink.
6. Reinsert the cartridge(s) and run a priming cycle as per printer instructions.



Outlet Hole

Filling Hole

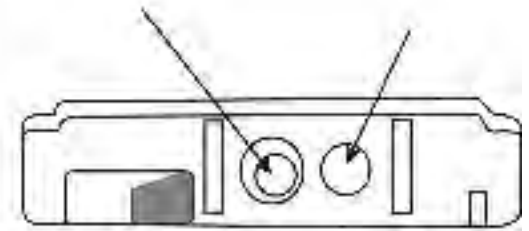

Note: Immediately refill any empty cartridge

1. Cut the label at joint between the top and bottom halves of the cartridge case.
2. Flip open the cartridge casing (shell).
3. Remove the cartridge from the casing (shell).
4. There is a round hole (well) in the top of the cartridge. Inside the hole or well is a rubber stopper. Use a thumb drill and drill through the rubber stopper.

Note: Do not bump or press the “pressure release button”.

5. Attach the needle onto the syringe and fill the syringe with 10 ml of ink.
6. Insert the needle through the drilled stopper hole and into the cartridge body. Please be sure the needle does not press up against the bag or puncture it, as this will ruin the cartridge and make it unusable.
7. Very slowly inject the 10ml of ink into the cartridge bag. If ink starts to come out of the filling hole, stop, as the cartridge is now full (pull back 1ml of ink from the cartridge back into the syringe to insure that the cartirdge is not over-filled). Unused ink can be returned to the bottle.
8. Remove the syringe with needle from the cartridge and seal the hole using the green tape dots provided or electrical tape. Make sure the hole is sealed airtight.
9. Place the cartridge back into its casing (shell) and use a piece of tape to hold the two sides of the casing (shell) together.
10. Re-install the cartridge back into the printer and run 1 to 3 cleaning cycles as per printer instructions.

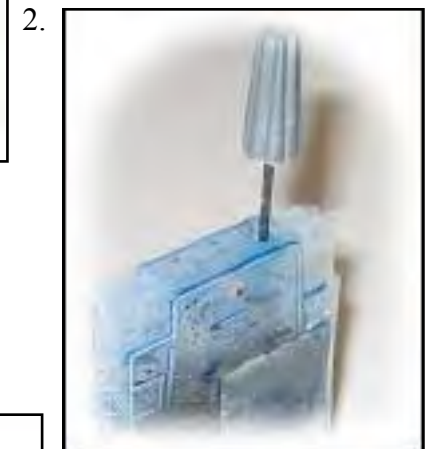

Brother Cartridges

**LC61C, LC61M, LC61Y, LC61BK,
LC65BK, LC65C, LC65Y, LC65M**

1. Stand the cartridge on a towel or ink spillable table. Using the eyelet screw provided, begin twisting the screw into the front of the cartridge (see illustration to the right). Continue twisting until it pierces the plastic..
2. Connect the needle to the syringe and fill with ink.
3. Insert the syringe into the hole and inject about 20 ml. (or until the cartridge is full but not overfilled) of ink.
4. Seal the filling hole with one of the silicon plugs included. You will need to make adjustments to the plug so that nothing stands out or bulges out once its inserted.
5. After you have made the necessary adjustments, use a small flat head screw to seal newly made hole (1/8" screw). You will want to make sure this area is flat to the surrounding surface when finished. *(This is very important since this is part of the area that will slide into the cartridge slot in the printer. If this area bulges out to far, it can pull off the area you just sealed and cause the cartridge to leak)*
6. Your cartridge has now been refilled and is ready for use.
7. Rinse the syringe with water and dry between each color refill or store for future use.

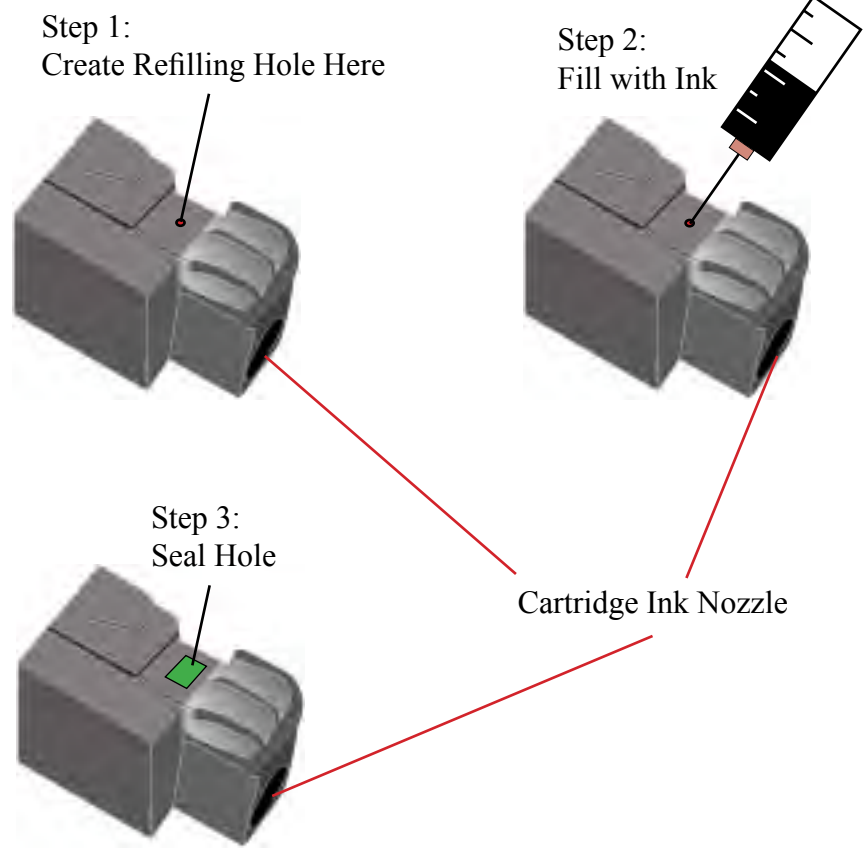
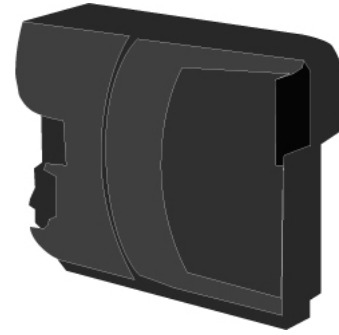

Canon Cartridges

**BCI-21 Black & 24 Black
BCI-21 Color & 24 Color**

1. Use a knife to remove the top of cartridge(s).
2. Use the included eyelet screw to enlarge the filling hole(s) in the top of the cartridge(s).
3. Connect the needle to the syringe and fill with ink.
4. Insert the syringe into the correct filling hole, (See diagram below for filling hole color) and push into the center of the cartridge. Note: You may feel a slight pressure because the cartridge contains a sponge.
5. Inject up to 5 ml. of ink, per color, into the cartridge.
6. Reposition the top and secure with a piece of tape.
7. Rinse the syringe with water and dry between each color filling or store for future use.
8. Reinsert the cartridge(s) and run a cleaning cycle as per printer instructions.

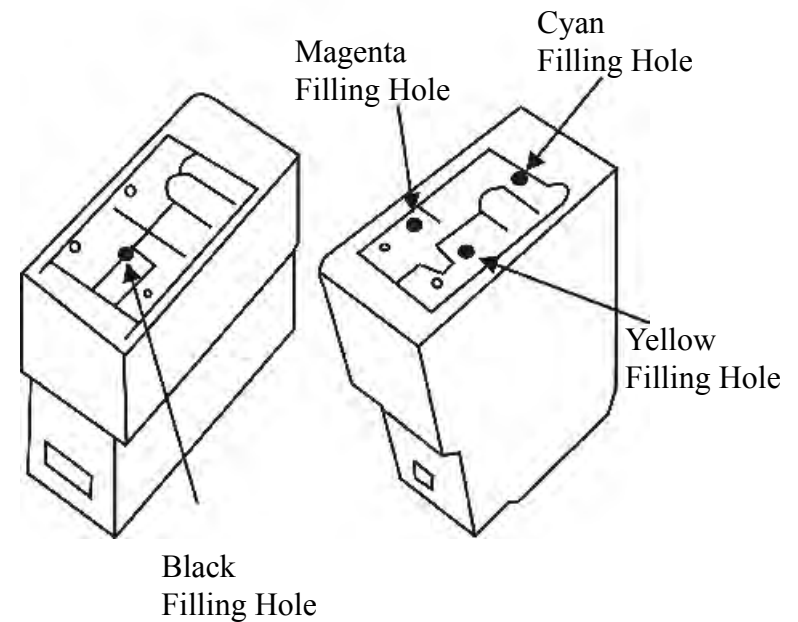
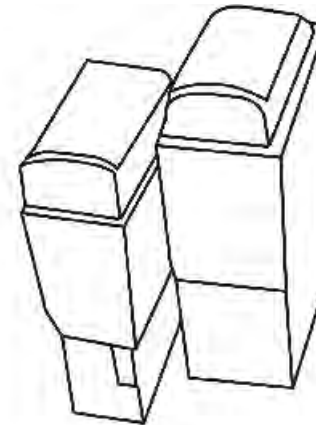

Canon Cartridges

BC-20 & BC-23 High Capacity Cartridge

1. Use the eyelet screw to remove plug located on top of the cartridge.
2. Connect the needle to the syringe and fill with ink.
3. Insert the syringe through the filling hole and push into the cartridge. Note: You may feel a slight pressure because the cartridge contains a sponge.
4. Inject up to 30 ml. of ink then reseal the cartridge with the plug that was removed from step 1.
5. Rinse the syringe with water and dry for future use, or use with a different color ink.
6. Reinsert the cartridge(s) and run a priming cycle as per printer instructions.

Note: Immediately refill any empty cartridges.

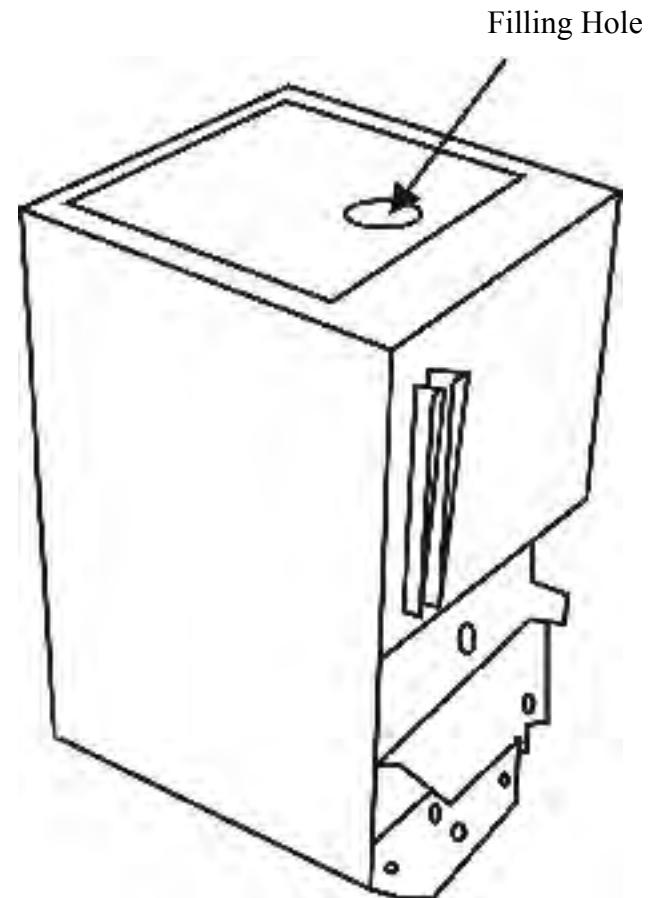

Canon Cartridges

BJI-201BK HC, BJI-201BK, BJI-201C, BJI-201M, BJI-201Y

1. With the cartridge upside down, using a screwdriver, push in the ball bearing that seals the filling hole. **NOTE: There are several versions of these cartridges. One version has the filling hole under the label on the top of the cartridge. Another version does not have a ball bearing at all. In this case it would be necessary to make a hole for the needle to be inserted. Make this hole in the same spot where the ball bearing would be located, as shown below. Seal hole with the plug provided.**
2. Connect the needle to the syringe and fill with ink.
3. Inject about 5 ml. of ink into the filling hole until the tank is full.
4. Use the included plug to seal the filling hole, make sure that the plug is sitting flush in the cartridge. **Additional Note: If the cartridge has been empty/dry, the sponge will no longer accept any ink which will cause the cartridge to leak.**
5. Rinse the syringe with water and dry for future use, or use with a different color ink.
6. Reinsert the cartridge and run a priming cycle as per printer instructions.

Note: Immediately refill any empty cartridges.

Filling Hole

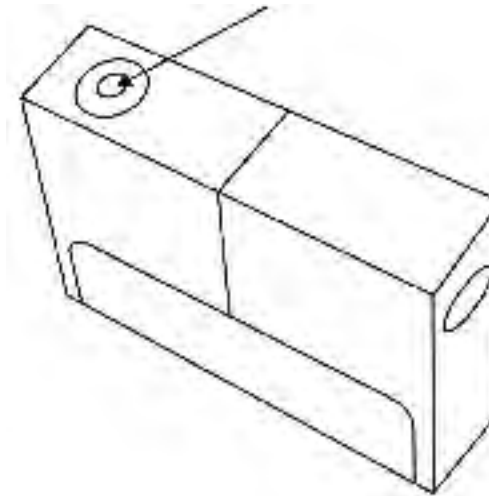

Outlet Hole

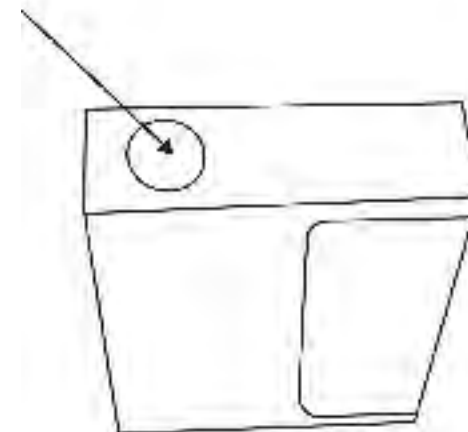

Canon Cartridges

BC-01, BC-02, BC-05, BX-02, BX-03, BC-06 (photo)

1. Use the eyelet screw to remove plug located on the top side of the cartridge.
FOR BX-03 ONLY: A hole must be made on the top of the cartridge by using the hole making tool included in the kit. . Firmly hold the handle of the tool and begin twisting the tool into the top corner of the cartridge. Continue twisting until it pierces the plastic cover. Once the plastic is pierced, making the rest of the hole will go very quickly.
2. Connect the needle to the syringe and fill with ink.
3. Insert the syringe through the filling hole and push into the cartridge. Note: You may feel a slight pressure because the cartridge contains a sponge.
4. Inject up to 30 ml. of ink then reseal the cartridge with the plug that was removed from step 1. **FOR BX-03 ONLY:** Use the plug provided in the kit to seal the cartridge.
5. Rinse the syringe with water and dry for future use, or use with a different color ink.
6. Reinsert the cartridge(s) and run a priming cycle as per printer instructions.

Note: Immediately refill any empty cartridges.

Black
Filling Hole

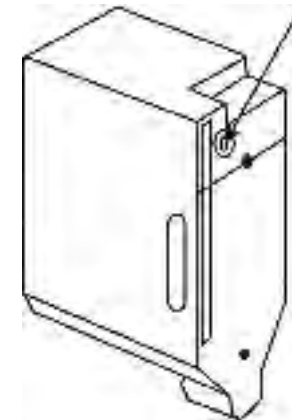

Printer Head

Cyan
Filling Hole

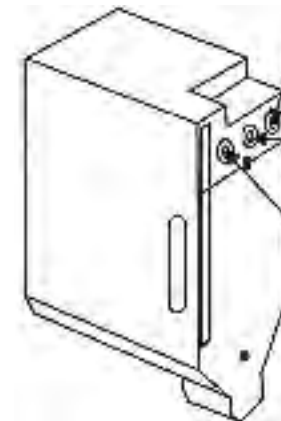

Magenta
Filling Hole

Yellow
Filling Hole

Printer Head

Canon Cartridges

**BCI-60, BCI-61, BCI-62
(photo)**

1. The filling holes are located under the label as shown. Just peel back the label leaving it still connected to the cartridge, do not remove completely.
2. Use the provided eyelet screw to widen the filling hole(s) in the top of the cartridge(s).
3. Connect the needle to the syringe and fill with ink.
4. Insert the needle into the widen filling hole. *Note: This cartridge has a sponge so you may feel a slight pressure. Inject about 10 ml. of ink, per color until the ink bubbles up.*
5. Pull the label back into place and use a piece of tape to hold it in place.
6. Rinse the syringe with water and dry between each color refill or store for future use.
7. Reinsert cartridge back into the printer and run 1 - 3 cleaning cycles as per printer instructions.

Note: Immediately refill any empty cartridge

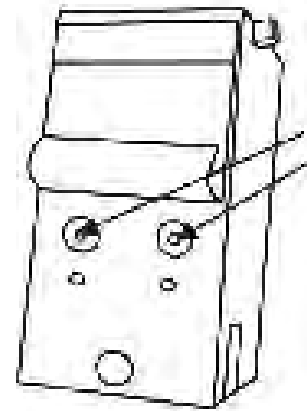

Black
Filling Hole

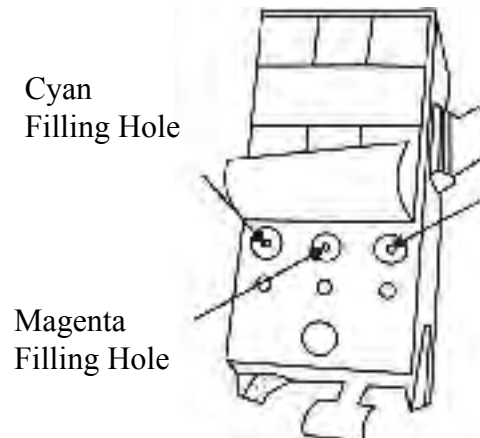

Cyan
Filling Hole

Magenta
Filling Hole

Yellow
Filling Hole

Canon Cartridges

*Note: Some models may require chip resetters.
Check with your vendor for availability.*

**BCI-3eBk, BCI-3eC, BCI-3eM, BCI-3eY, BCI-3Bk, BCI-3C, BCI-3M,
BCI-3Y, BCI-3PBk, BCI-3PC, BCI-3PM, BCI-5Bk, BCI-5C, BCI-5M,
BCI-5Y, BCI-5PC, BCI-5PM, Cli-8Bk, Cli-8C, Cli-8M, Cli-8Y, Cli-8PBk,
Cli-8PC, Cli-8PM, PGI-5, PGI-220, CLI-221**

1. Use electrical or duct tape to seal the Air Vent found on the top of the cartridge.
Note: Make sure tape is completely covering the vent.
2. Remove the label partially, only to expose the ball bearing underneath. Then use a screwdriver or an L tool to push the ball bearing into the cartridge. This will give access to the filling hole.
3. Connect the needle to the syringe and fill with ink.
4. Use your finger as a plug by covering the outlet port. Keep your finger on the outlet port until you have finished refilling and the refill hole is plugged. If you let go any time earlier, ink may and can spill out of that outlet.
5. Inject about 10 ml. of ink into the filling hole or until the ink chamber is full. Be sure to leave enough room in the ink chamber for the silicon plug, it will create pressure when inserted.
6. Put a silicone plug in the refill hole to seal it, make sure it is air tight. If extra silicone from the plug is sticking out, you may trim it down to a practical size. Be sure to leave enough to make it easy for you to remove the next time you wish to refill the cartridge.
7. Remove your finger from the outlet (small drops may leak out, but once the cartridge pressure stabilizes itself, it will stop) and remove the tape from earlier off the vent.
8. Rinse the syringe with water and dry for future use, or use with a different color ink.
9. Reinsert the cartridge and run a priming cycle as per printer instructions.

Note: If the cartridge continuously leaks, place the cartridge on its side until the dripping stops. Also, check the seal on the cartridge to make sure it is airtight.

[CLICK HERE TO GO THE INDEX](#)

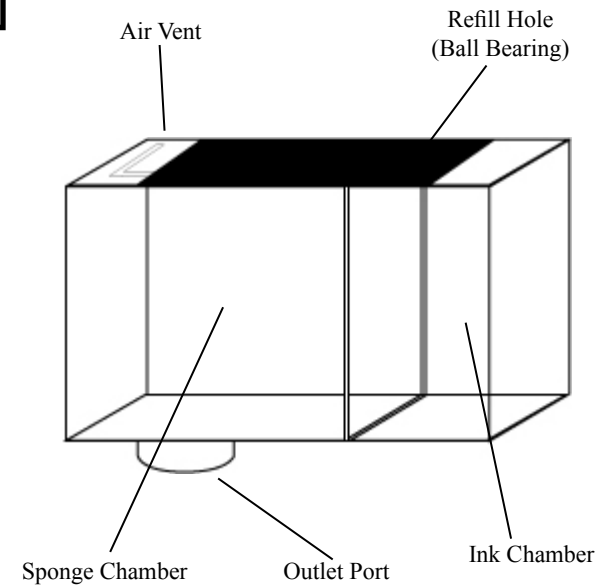

Push in the ball bearing (may require some force)

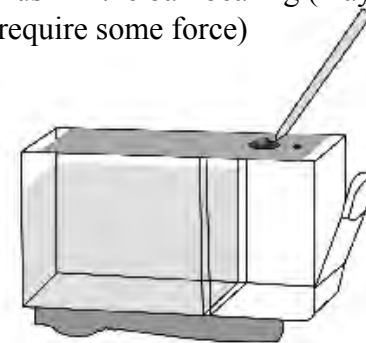

Canon CLI-8

Canon Cartridges

**BC-22e
(photo)**

1. Use the eyelet screw to remove the plugs located on top of the cartridge.
2. Connect the needle to the syringe and fill with ink.
3. Insert the syringe through the filling hole and push into the cartridge. Note: You may feel a slight pressure because the cartridge contains a sponge.
4. Inject up to 10 ml. of ink, per color, then reseal the cartridge with the plug that was removed from step 1.
5. Rinse the syringe with water and dry for future use, or use with a different color ink.
6. Reinsert the cartridge(s) and run a priming cycle as per printer instructions.

Note: Immediately refill any empty cartridges.

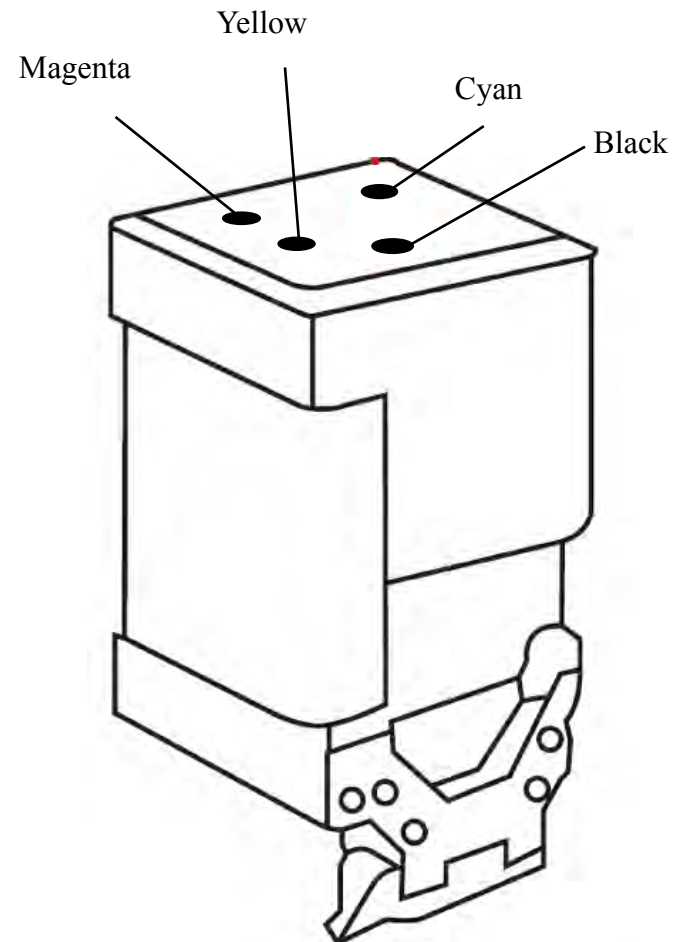

Canon Cartridges

1. Remove label from the top of cartridge
2. Using the drill tool, widen the refill holes for each color. Please use the illustrations on the right as guidance.
3. Prepare an area for refilling.
4. Attach the needle to syringe and load syringe with 6ml of ink (For color cartridges) position for the 41, 51, 52 cartridges or 20ml for the black 40 and 50 cartridges.
5. Insert needle into correct color ink hole (that you created in the vent). Penetrate the sponge inside and be sure the needle does not reach the bottom of cartridge.

If the needle penetrates to the bottom of the cartridge, the cartridge will leak and is not salvageable.

6. SLOWLY inject the ink into the cartridge. Stop if the ink begins to well up from the fill hole. Reverse the process and pull about 1ml of ink if it has spilled out the top of the cartridge.
7. Clean off top of cartridge, un-tape the next fill hole and tape over the one just filled. This is so you don't accidentally contamination other colors.
8. Repeat steps 5, 6, 7, 8 until all colors have been injected.
9. Clean off the top of the cartridge. Place tape over the top of the cartridge so it covers every hole.
10. Use a pin and put a small hole (vent hole) through the tape for each hole on the top of the cartridge.

This is important, don't skip this step. The cartridge must be vented to atmosphere or it will not work.

11. Reinstall in printer and run one or two cleaning cycles until the cartridge begins to print correctly.

PG-30/PG-40/PG-50
PG-210

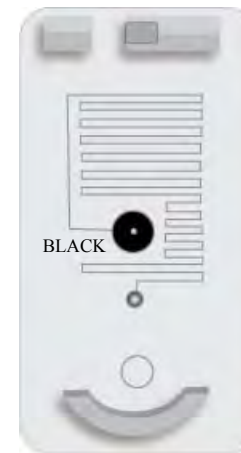

CL-31/CL-41/CL-51
CL-211

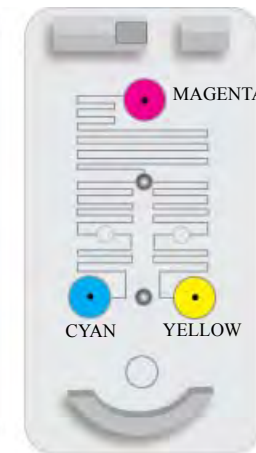

CL-52

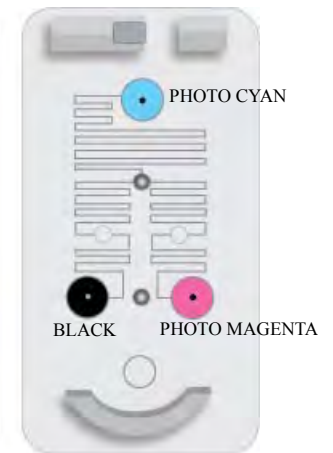

Compaq Cartridges

Black Cartridges:

337714-001, 180845-001, 337709-001, 180847-001

1. Use the enclosed eyelet screw to enlarge the filling hole located at the top of the cartridge. (Do not remove the cap.)
2. Connect the needle to the syringe and fill the syringe with 8 ml. of Cartridge & Print Head Cleaner and inject into the cartridge. Reinsert cartridge into printer and print 5 test pages.
- 3 Fill the syringe with ink. Insert the needle into the filling hole and push down into the cartridge. Inject up to 20 ml. of ink or until the cartridge is full.

Note: Immediately refill any empty cartridges.

Color Cartridges:

337715-001, 180846-001, 337710-001, 180848-001, 180844-001,

Photo cartridges:

337711-001(photo)

1. The filling holes are located under the plastic cap. Use a thin flathead screwdriver or knife to remove the cap. **Important: Do not to damage the sensors on the back of the cartridge.**
2. Connect the needle to the syringe and fill with ink.
3. Insert the needle into the matching hole of the color to be refilled, (see diagram above) and push into the cartridge. **Note: You will feel a slight pressure because the cartridge contains a sponge.**
4. Inject about 8 ml. of ink, per color, into the cartridge until the ink begins to bubble at the top of the sponge. **Important: Do not overfill. Keep the sponge inside the cartridge white.**
5. Rinse the needle and syringe with water and dry between each color refilling or store for future use.
6. The cover can be reattached with a piece of tape.

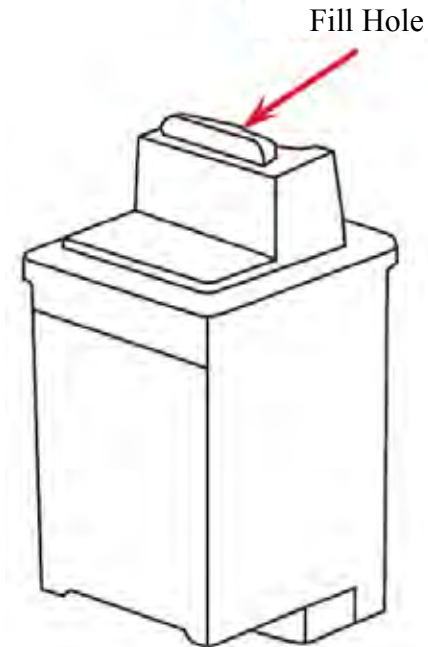

Cyan

Yellow

Magenta

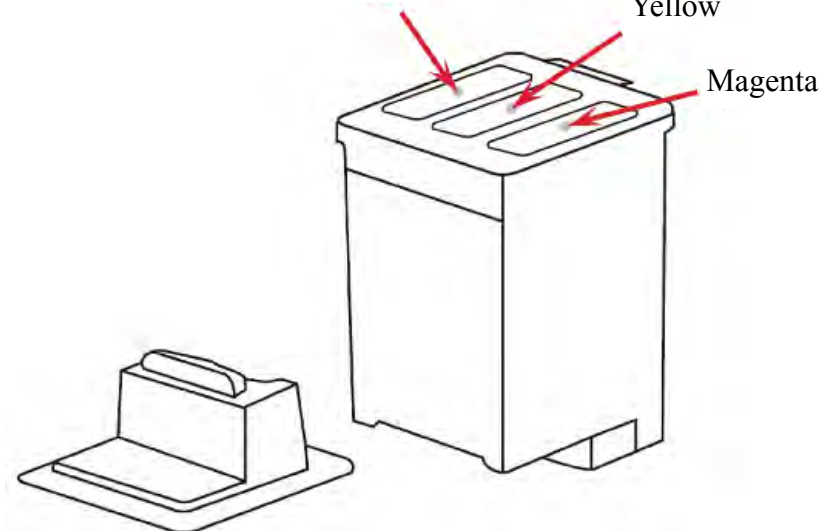

Dell Cartridges

Black Cartridges: 7Y743, T0529, T0601

1. Use the enclosed eyelet screw to enlarge the filling hole located at the top of the cartridge. (Do not remove the cap.)
2. Connect the needle to the syringe and fill the syringe with 8 ml. of Cartridge & Print Head Cleaner and inject into the cartridge. Reinsert cartridge into printer and print 5 test pages.
- 3 Fill the syringe with ink. Insert the needle into the filling hole and push down into the cartridge. Inject up to 20 ml. of ink or until the cartridge is full.

Note: Immediately refill any empty cartridges

Color Cartridges: 7Y745, T0530, T0602

1. The filling holes are located under the plastic cap. Use a thin flathead screwdriver or knife to remove the cap. Important: Do not to damage the sensors on the back of the cartridge.
2. Connect the needle to the syringe and fill with ink.
3. Insert the needle into the matching hole of the color to be refilled, (see diagram above) and push into the cartridge. Note: You will feel a slight pressure because the cartridge contains a sponge.
4. Inject about 8 ml. of ink, per color, into the cartridge until the ink begins to bubble at the top of the sponge. Important: Do not overfill. Keep the sponge inside the cartridge white.
5. Rinse the needle and syringe with water and dry between each color refilling or store for future use.
6. The cover can be reattached with a piece of tape.

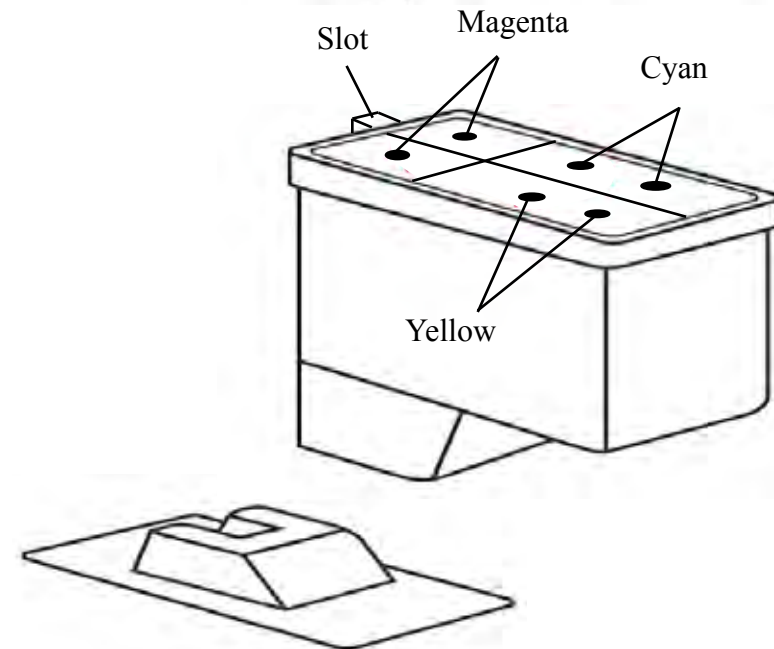
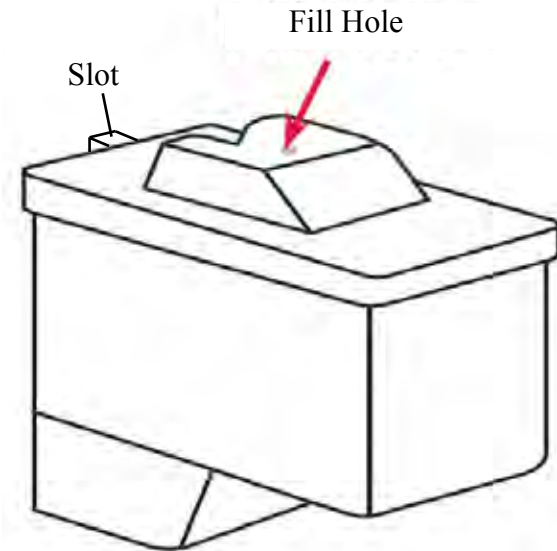

Digital Cartridges

LJ50X-AB, LJ50X-AK, LJ50X-AC Color Cartridge

1. The filling holes are located under the cap. The cap is easily removed by simply pulling it off with your fingers. Be careful not to damage the sensors on the back
2. Connect the needle to the syringe and fill with ink.
3. Insert the needle into the filling hole of the color to be refilled, pushing it down into the cartridge. **Note: You may feel a slight pressure because the cartridge contains a sponge.**
4. Inject about 8 ml. of ink, per color, or until the ink bubbles at the filling hole.

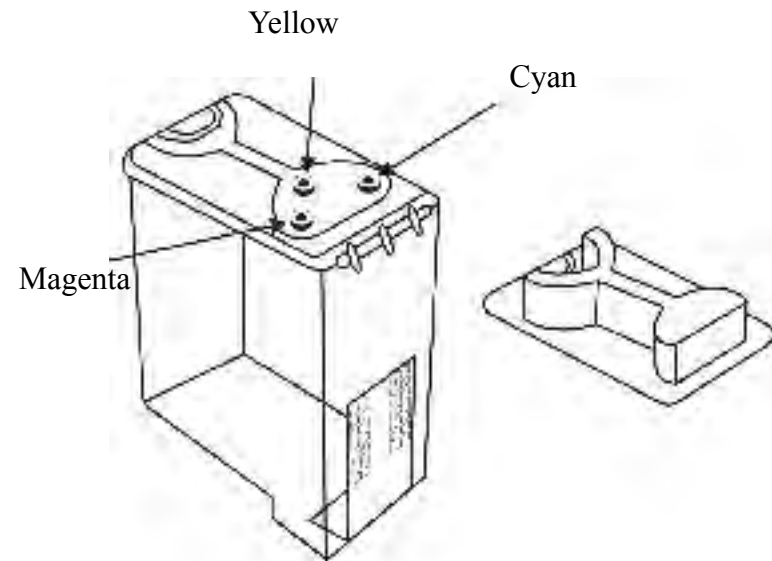

Black Cartridge

1. The actual cartridge is located inside a plastic shell. To remove it pry the locking tab out and pull the cartridge out of the plastic shell. **Important: All of the parts in the cartridge are very sensitive and delicate and should not be touched. They can be damaged easily.**
2. Using a screwdriver remove the plug (not shown) from the filling hole. (Do not remove the top).
3. Fill the syringe with ink, insert the filling needle into the filling hole and push 3/4 of the way into the cartridge. Inject about 15 ml. of ink or until the ink tank is full.
4. Slide the cartridge back into the plastic shell and reinsert into the printer.

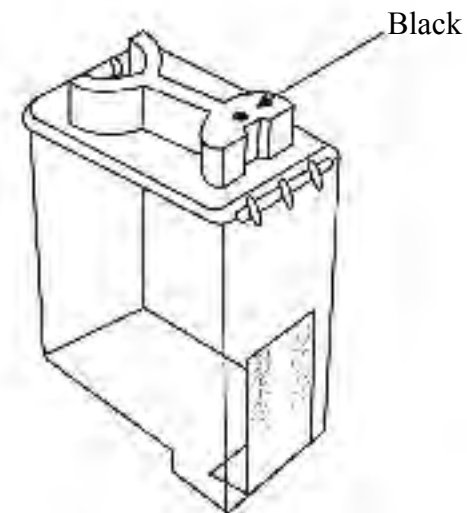

Epson Cartridges

S020062, S020118, S020122, S020130

1. The filling hole is the same hole as the hole that connects to the printer.
2. *Note: The cartridge is lined in a delicate Mylar bag and it is very important not to insert the needle more than 3/4" or it is possible to pierce or tear the Mylar bag. Fill the syringe with the correct color ink and carefully insert the needle into the filling hole and slowly inject approximately 90 ml. of ink into the cartridge.*
- 3 Hold the cartridge upright with the filling hole at the top. Using the syringe, remove any trapped air in the cartridge by only inserting the tip of the needle and pulling up on the plunger until all air is removed.
4. Remove the syringe and rinse with water and dry for future use, or to use with a different color ink.
5. Reinsert the cartridge and run a priming cycle as per printer instructions.

Note: Immediately refill any empty cartridges.

NOTE: It is not necessary to disassemble the cartridge to refill it and we strongly recommend you do not. We have included a picture of the inside of the cartridge to satisfy your curiosity.

M with PM
or
C with PC

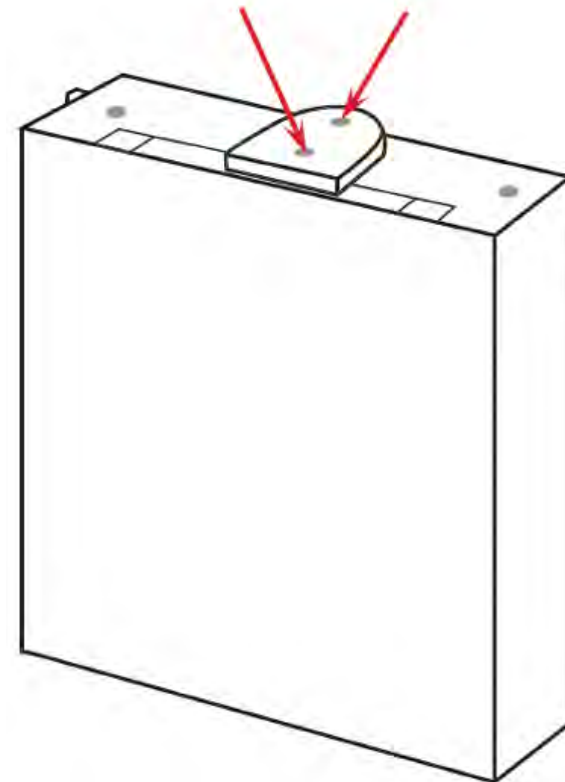

Epson Cartridges

*Note: Some models may require chip resetters.
Check with your vendor for availability.*

**S020093, S020097, S020110, S020193,
S020187, S020189, S020191, S020089, S020093,
S020108, S020047, S020049, S020097, S020034, S020036, S020138,
T001, T003011, T003012, T005011,**

**T007201, T008, T008201, T009, T009201, T013, T014, T015201,
T016201, T017, T018, T019201, T020201, T026, T027, T028, T029,
T036120, T037020, T040120, T041020**

1. Put a piece of tape over each outlet hole(s) at the bottom of the cartridge.
2. Connect the needle to the syringe. Before filling the syringe with ink, use the needle tip to pierce through the label to create the filling hole. Then fill the syringe with the appropriate color ink.
3. Slowly inject approximately 8 ml. of ink, per color, until the cartridge is full.
4. Use tape to seal the hole(s) made in the top of the label.
5. Rinse the syringe with water and dry between each color refill or store for future use.

Follow this step for cartridges WITHOUT the smart chip:

6. Leave the tape on the outlet hole(s) and insert the cartridge into the printer and run 1 - 3 cleaning cycles as per printer instructions. It may be necessary to leave cartridge in printer for up to 24 hours to allow ink to flow to the print head.

NOTE: If cartridge is refilled before it is completely empty this time is greatly reduced.

Exit Hole

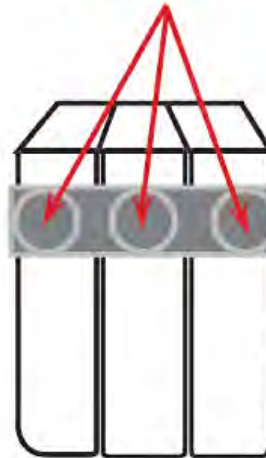

Fill Hole

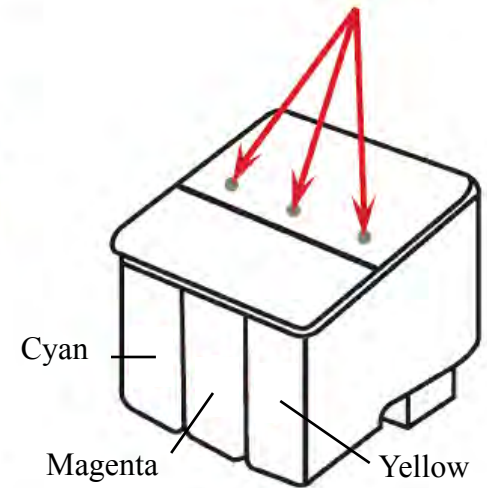

Fill Hole

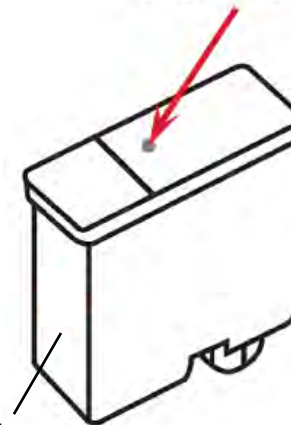

Fill Hole

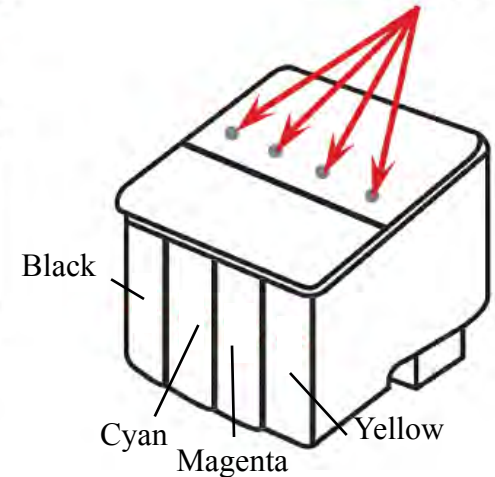

Epson Cartridges

*Note: Some models may require chip resetters.
Check with your vendor for availability.*

**T0321, T0322, T0323, T0324, T0331, T0332, T0333, T0334, T0335,
T0336, T0341, T0342, T0343, T0344, T0345, T0346, T0347, T0348,
T0422, T0423, T0424, ICD Y21**

1. Turn the cartridge upside down and using a paper clip or a similar object, pierce through the label into the cartridge of the proper filling hole (as shown below).
2. Connect the needle to the syringe and fill with ink.
3. Inject about 5 - 7 ml. of ink into the filling hole until the cartridge is almost full. Be aware that the needle will only go into the cartridge about 3/8 of an inch.
4. Use the tape dot to seal the filling hole, make sure it is completely sealed.
5. Rinse the syringe with water and dry for further use, or use with a different color ink.
6. Follow the resetting instructions before inserting cartridge into printer.

Note: Immediately refill any empty cartridges.

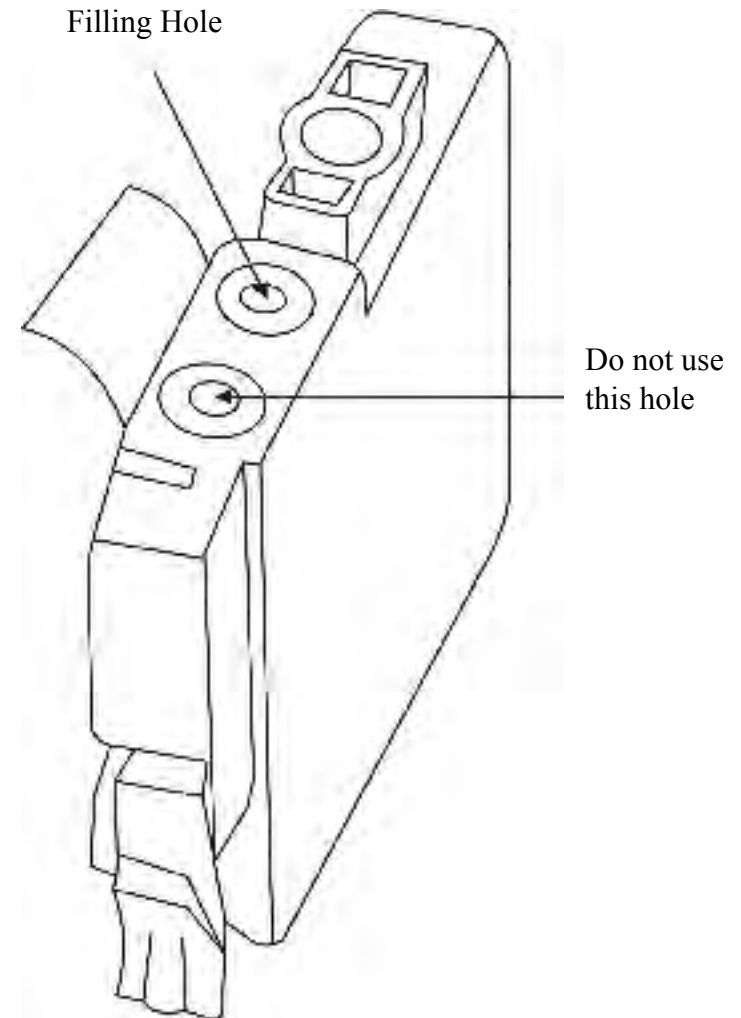

Epson Cartridges

*Note: Some models may require chip resetters.
Check with your vendor for availability.*

**T0431, T0441, T0442, T0443, T0444, T0481, T0482, T0483, T0484,
T0485, T0486, T0540, T0541, T0542, T0543, T0544, T0545, T0546,
T0547, T0548, T0549, T0601-T0604**

1. It is important to understand the sections of this cartridge before refilling. Please study diagram closely.
2. Using the eyelet screw, create a hole (see illustration to the right). Keep the screw centered when drilling the hole.
3. Connect the needle to the syringe and fill with the correct color ink.
4. Insert the needle into the newly created hole. Inject about 12 ml. of ink slowly into the filling hole until the cartridge is almost full.
5. Wipe the filling hole clean and dry and then insert a silicon plug. Depending on the sealing plug you receive, you may need to widen the hole to accommodate the new plug. Be sure to seal it air tight (not sealing it air tight could cause leakage while printing).
6. Rinse the syringe with water and dry for future use, or use with a different color ink.
7. Follow the resetting instructions before inserting the cartridge into printer.

Note: Immediately refill any empty cartridges.

Create Refill hole



Hewlett Packard Cartridges

51626A, 51629A, 51626G, 51629G, 51633M, C6614AN, C6628AN

For maximum success, using the HP bottom filler (sold separately) makes the filling of these HP inkjet cartridges easier and neater.

1. Put a piece of tape over (Aerator "B") on the bottom of the cartridge. This aerator must be sealed tightly to prevent leaking. - see diagram.
2. Aerator "C" is located in the center of the top of cartridge. DO NOT STICK THE NEEDLE IN THIS HOLE.
3. If you have a cartridge that has a ball bearing in the top corner of the cartridge then simply push in the ball bearing with a pointed object such as a screwdriver.
4. If you have a cartridge that does not have this ball bearing; a hole must be made in the top corner of the cartridge- see diagram. Use the hole making tool included in the kit or an Exacto Knife or a Drill Bit to make this hole. This hole must be made perfectly round.
- 4a. Remove the Hole Making Tool from its packaging then remove the cover from the tool to expose the blade. CAREFUL! Blade is sharp. Firmly hold the handle of the tool and begin twisting the tool into the top corner of the cartridge. Continue twisting until it pierces the plastic cover. Once the plastic is pierced, making the rest of the hole will go very quickly.

IMPORTANT: Do not make a hole as big as the tool itself. The plug provided must fit tightly in order for a perfect air tight seal.

5. Connect the needle to the syringe and pull back on the plunger to fill with cartridge and printhead cleaner. Inject approximately 2 cc's of cleaner. It is not necessary to seal the cartridge. Let the cartridge sit for about 2 minutes. To remove the cleaner, turn the cartridge over and let it drain out of the filling hole.
6. Now turn the cartridge upright on a paper towel and fill with 20 ml. of ink through the filling hole on the top corner of the cartridge.
7. Squeeze the sides of the cartridge while sealing the hole with the plug included. **Optional: To insure that it is sealed airtight, cover the plug with a piece of electrical tape.**

8. Rinse the syringe with water and dry for future use.

9. Now remove the tape over (Aerator "B").

10. If the cartridge continues to drip ink, Insert ONLY the tip (no more than 1/8 inch) of the needle into (Aerator "C"), hold the cartridge over a sink or paper towels. Pull back on the plunger of the EMPTY syringe to 2 cc's and push down on the plunger to pump 2 cc's of air into cartridge. Important: Do NOT insert the needle more than 1/8 inch into aerator C as you will damage the cartridge.

11. Ink will now drip from the nozzles. Blot the nozzles with the tissue until ink stops dripping.

12. Reinsert cartridge into printer and run several test cycles until print quality is restored.

Note: Allow the cartridge to sit outside the printer overnight to restore print quality. Note: Immediately refill any empty cartridges.

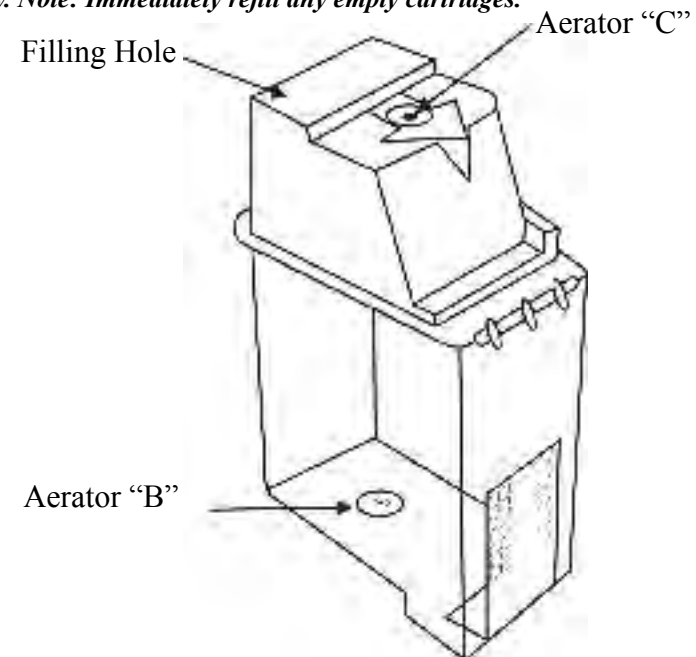

Hewlett Packard Cartridges

51625A, 51649A , 51649G, C1816A (photo)

1. The plastic cover must be removed to reveal the filling holes. Carefully pry it off with a thin metal blade, such as a thin flathead screwdriver. Or lay the cartridge on its side with the plastic cap off the edge of a table holding it firmly then break the seal by striking it with a blunt object. **Important: Make certain that the sensors on the back of the cartridge do not get damaged.**
2. Connect the needle to the syringe and fill with the correct color of ink.
3. Insert the needle into the hole of the color to be refilled, (see diagram above) and push directly down into the cartridge. **Note: You may feel a slight pressure due to the sponge inside the cartridge.**
4. Slowly inject approximately 7 ml. of ink, per color, into the cartridge. Stop when the ink begins to surface. **Important: The sponge inside is white. And in order to prevent overfilling the chamber, the color of the sponge must remain white. As soon as the ink starts to bubble near the needle then stop injecting, the cartridge is full.**
5. Rinse the syringe and needle with water and dry between each color refilling or store for future use.
6. The cover can be reconnected with a piece of adhesive tape.

Note: Immediately refill any cartridge that has become empty.

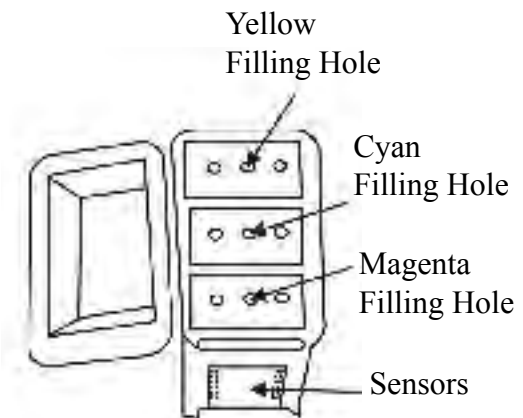
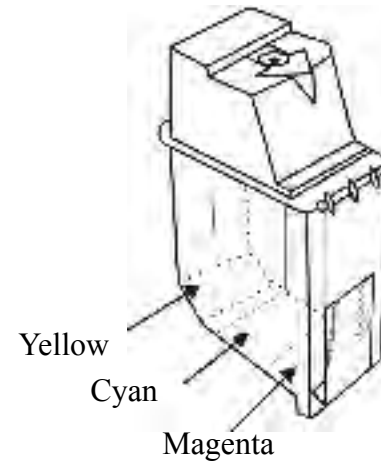

Hewlett Packard Cartridges

**51645A, 51645G, 51640A, 51640C, 51640M, 51640Y, 51644C,
51644M, 51644Y, C6615DN , C6615AN**

For maximum success, using the HP bottom filler (sold separately) makes the filling of these HP inkjet cartridges easier and neater.

1. Turn the cartridge upside down and using a peel back the plastic film covering the stainless steel ball bearing as shown below.
2. Using a screwdriver push the ball bearing into the cartridge.
3. Connect the needle to the syringe and fill with the correct color ink. Important: Do NOT insert the needle more than 1 inch into the cartridge as you may purchase the bag inside the cartridge.
4. Inject 20 ml. of ink into the hole.
5. Squeeze the sides of cartridge while sealing the filling hole with the included plug, make sure that the plug is seated flush against the cartridge.
6. Allow cartridge to sit with the print head down for at least 2 minutes to draw out any excess ink and equalize the pressure in the cartridge. **Important: Do not leave the cartridge resting a paper towel this will cause a wicking effect which will empty your cartridge.**
7. Rinse the syringe with warm water and dry between each color refill or store for future use.
8. Reinsert the cartridge and run a priming cycle as per printer instructions.

Note: Immediately refill any empty cartridges.

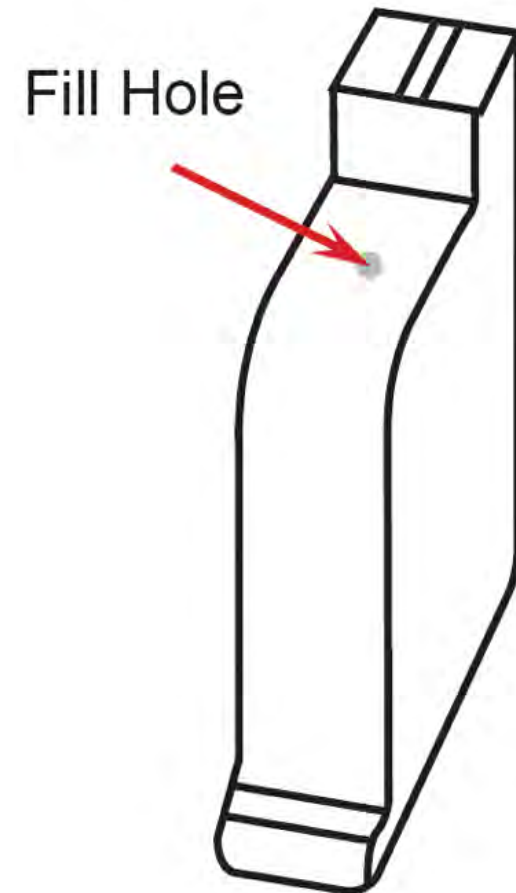

Hewlett Packard Cartridges

**51641A, C1823A, C1823D, C1823G, C6625AN,
C6578AN, C6578DN,
C3844A
(photo),**

C3845A (photo)

1. The small sealed holes on the top are the filling holes. Use a small screwdriver to push the plastic seals into the cartridge.
2. Connect the needle to the syringe and fill with the color ink you are going to fill.
3. Insert the needle into the filling hole of the color you are refilling, (see diagram above) and push all the way towards the center of the cartridge. **Note: The cartridge contains a sponge and resistance will be felt.**
4. Inject approximately 10 ml of ink, per color, or until ink just begins to bubble at the top of the filling hole. **Note: It is not necessary to reseal the filling holes.**
5. Clean the syringe with warm water, and dry before refilling with another color or for future use.

Note: Empty cartridges should always be filled immediately.

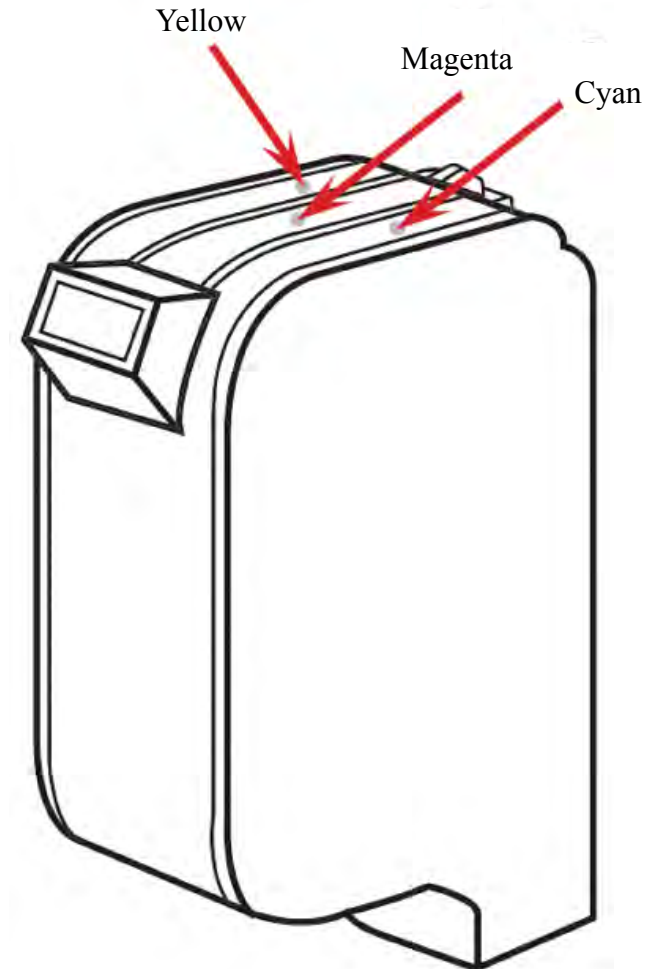

Hewlett Packard Cartridges

**C4841A, C4842A, C4843A, C4844A
HP 38, HP 50, HP 70, HP 72, HP 82, HP 88, HP 940**

**Note: Some models may require chip resetters.
Check with your vendor for availability.**

1. Cut label at joint between top and bottom cap of cartridge case.
2. Flip back the bottom cap of cartridge.
3. Squeeze the sides of cartridge casing and wiggle out the Mylar ink bag and pump assembly from the insert lock.
4. Screw the eyelet screw into the center of the rubber sealing plug, (situated in the filling hole) until a firm grip is made and pull out the plug. (Do not pull the plug off the end of the eyelet screw.)
5. Inject the ink through the filling hole into the Mylar ink bag. (Do not insert the needle more than 1/2" into the bag or else the Mylar ink bag may be pierced.)
6. Fill with ink until ink appears at the bottom of the filling hole. Reseal with the plug on the end of the screw and then remove the screw from the plug.
7. Remove the excess air from the Mylar ink bag and pump assembly as follows:
 - A. Hold assembly at a 45° angle with outlet hole at the top.
 - B. Insert needle of empty injector (with plunger pushed in) into outlet hole.
 - C. Press and release cartridge pump several times which will push air into the syringe.
 - D. Pull back the plunger on the syringe to remove any air from the outlet hole then remove the needle.
8. Replace the Mylar ink bag assembly into the cartridge case and clip the bottom back into position.
9. Install the cartridge back into printer.

Note: Immediately refill any empty cartridges.

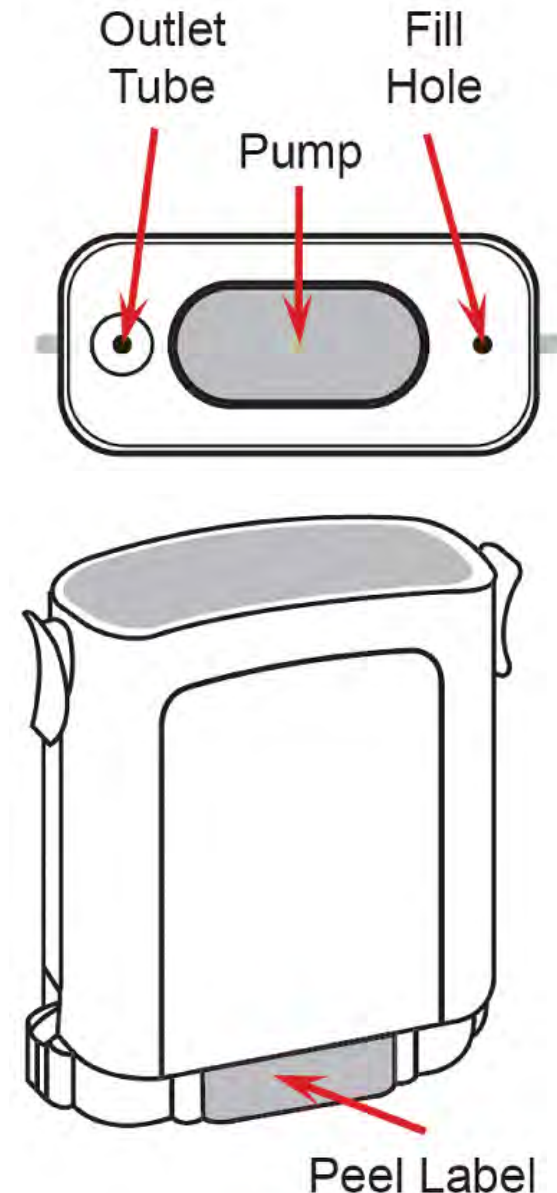

Hewlett Packard Cartridges

Models #'s listed to the right above the cartridge diagrams

1. Peel back the label from the top of the cartridge to expose the refill holes of the cartridge. *(If the illustration on the right differ from your cartridge model, use 3 toothpicks and poke each hole to determine its color)*
2. Fill the syringe with 15ml of black ink *(5ml for each color on color cartridges)*.
3. Insert the needle into the cartridge (corresponding with the correct color ink) and fill. If to much ink is inserted, pull back on the syring handle to pull 1ml out.

IMPORTANT: When refilling, only puncture the top of the sponge in the cartridge, about 1/8 to 1/4 inch. Puncturing to the bottom may cause leakage in the cartridge.

4. Stick the label back in place, if the label has been destroyed, use duct tape or electrical tape. *(Try keeping the label size when using tape)*
5. Rinse the syringe with water and dry between each color refill or store for future use.
6. Reinstall the cartridge and run 1 - 3 test pages as per printer instructions. If necessary leave the cartridge in printer for up to 24 hours to allow ink to flow to the print head.

NOTE: Cartridges that are not refilled right away may and can dry with time. For the best results, refill right after the cartridges are depleted.

Cartridge Model #'s
21/27/56/74/74XL
92/94/96/98

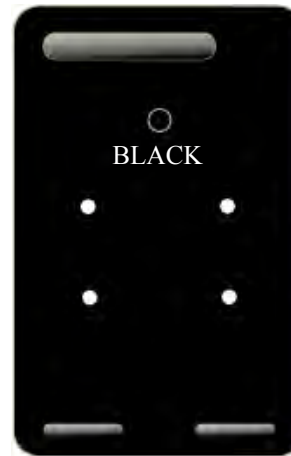

Cartridge Model #'s
60/75/75XL/93/
95/97/110/901

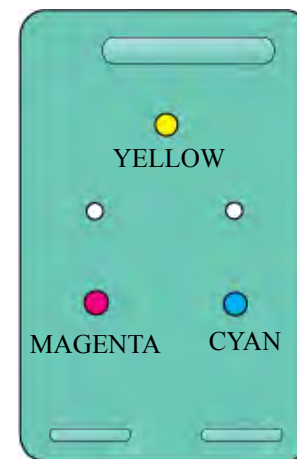

Cartridge Model #'s
22/28/57

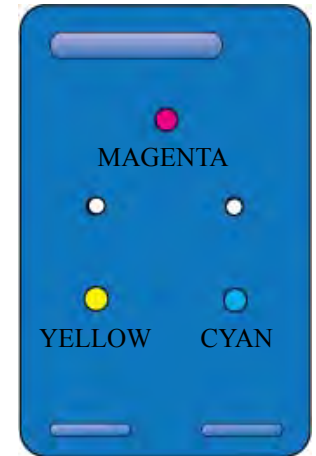

Cartridge Model #'s
99

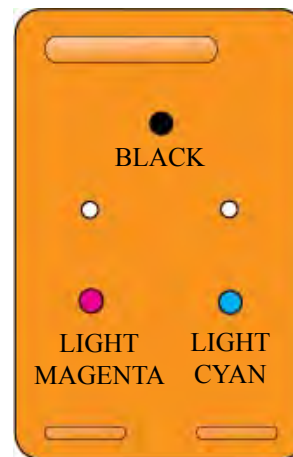

Cartridge Model #'s
58

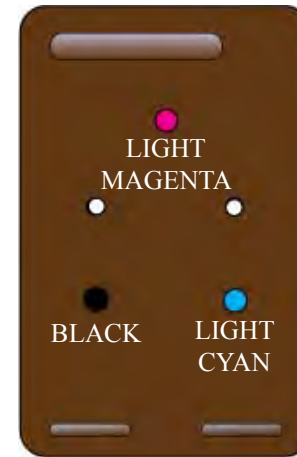

Cartridge Model #'s
60 and 901



HP Cartridges

HP 564 and 920

*Note: Some models may require chip resetters.
Check with your vendor for availability.*

1. Use electrical or duct tape to seal the Air Vent found on the top of the cartridge.
Note: Make sure tape is completely covering the vent.
2. Remove the label partially, only to expose the ball bearing underneath. Then use a screwdriver or an L tool to push the ball bearing into the cartridge. This will give access to the filling hole.
3. Connect the needle to the syringe and fill with ink.
4. Use your finger as a plug by covering the outlet port. Keep your finger on the outlet port until you have finished refilling and the refill hole is plugged. If you let go any time earlier, ink may and can spill out of that outlet.
5. Inject about 10 ml. of ink into the filling hole or until the ink chamber is full. Be sure to leave enough room in the ink chamber for the silicon plug, it will create pressure when inserted.
6. Put a silicone plug in the refill hole to seal it, make sure it is air tight. If extra silicone from the plug is sticking out, you may trim it down to a practical size. Be sure to leave enough to make it easy for you to remove the next time you wish to refill the cartridge.
7. Remove your finger from the outlet (small drops may leak out, but once the cartridge pressure stabilizes itself, it will stop) and remove the tape from earlier off the vent.
8. Rinse the syringe with water and dry for future use, or use with a different color ink.
9. Reinsert the cartridge and run a priming cycle as per printer instructions.

Note: If the cartridge continuously leaks, place the cartridge on its side until the dripping stops. Also, check the seal on the cartridge to make sure it is airtight.

[CLICK HERE TO GO THE INDEX](#)

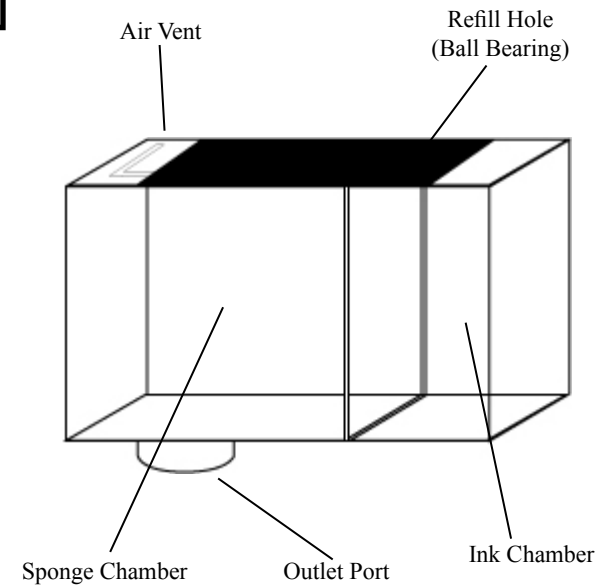

Push in the ball bearing (may require some force)

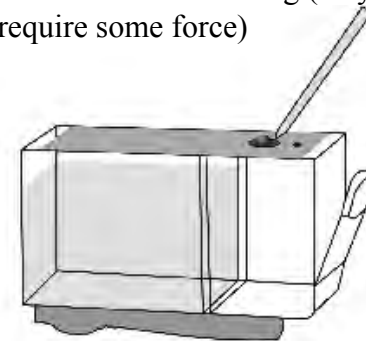

Hewlett Packard Cartridges

C1806A, C1807A, C1808A, C1809A

1. Remove the Mylar ink bag from the cardboard covering. *Note: (This Mylar ink bag is very delicate and must be handled with care).*
2. Use both hands when holding the top of the Mylar bag and use both thumbs to pry the hose cap off of the connector. (Pop off the connector the same way you would pop off the cap of an aspirin bottle. Be very careful not to damage the connector.) Make certain not to misplace or damage the o-ring. It must be in the same position shown below before the hose cap assembly can be reinstalled.
3. Connect the needle to the syringe and fill with ink.
4. Hold the bag upright and inject up to 60 ml of ink or until 3/4 full. Do not fill completely because you need room to install the hose cap assembly. *Note: (After filling do not squeeze the Mylar bag as this will cause ink to squirt out of the connector.)*
5. Hold the top of the Mylar bag and using both thumbs reinstall the hose cap assembly. You can grasp the block at the base where the assembly is installed into the Mylar bag. Make sure the hose cap assembly is firmly attached to the connector. You will feel two clicks when reinstalling the hose cap assembly.
6. Put the Mylar bag back into the cardboard covering and install into machine.
7. Rinse the syringe and needle with water between each color refilling and dry for future use.

Note: Empty cartridges should be refilled immediately.

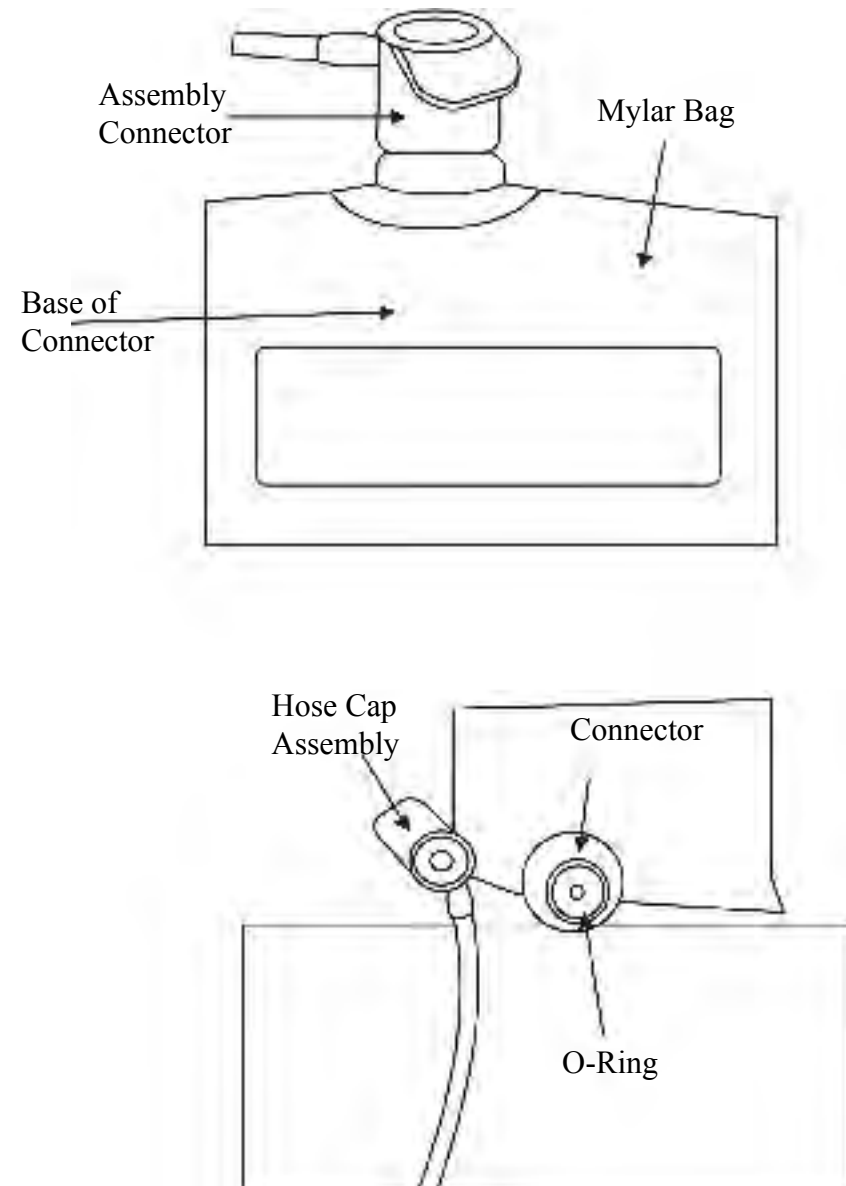

Hewlett Packard Cartridges

C5010A, C5011A

1. Connect the needle to the syringe. Using the needle, pierce through the label into the cartridge. *Note: We have removed the label to illustrate where the filling holes are located. We do not recommend removing it.*
2. After you have pierced the label, fill the syringe with the correct color of ink.
3. Insert the needle into the cartridge of the filling hole. Slowly inject ink into the cartridge is full. Use approximately 5 ml per chamber.
4. Use a piece of tape to seal the hole(s) made in the top label. *Note: The cartridge will leak if the holes are not sealed properly.*
5. Rinse the syringe with water and dry between each color refill or store for further use.
6. Reinstall the cartridge and run 1 - 3 test pages as per printer instructions. If necessary leave cartridge in printer for up to 24 hours to allow ink to flow to the print head.

NOTE: *This time is greatly reduced if the cartridge is refilled before it is completely empty.*

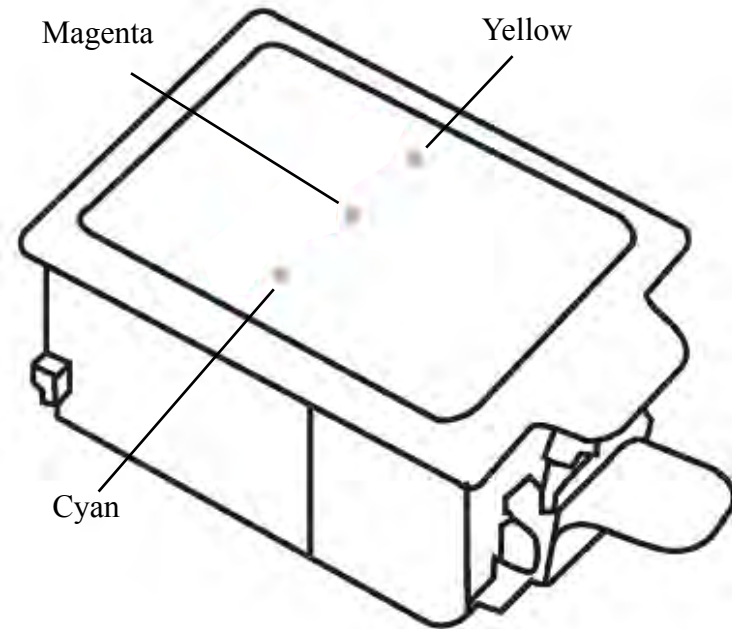

Hewlett Packard Cartridges

C6634A, C6635A

1. Drill filling holes on the top of the cartridge (as shown below left) or pry off the cartridge top as shown below right. Do the procedure that is easier for you. Use the hole making tool included in the kit, drill each filling hole on the top of the cartridge wide enough to fit the needle as shown below left. Or use a flathead screwdriver to pry off the top.
2. Connect the needle to the syringe and fill with the ink. **Note: All 3 filling holes must be refilled in the black cartridge.**
3. Insert the syringe through the filling hole and push all the way into the cartridge. **Note: You may feel a slight pressure because the cartridge contains a sponge.**
4. Slowly inject up to 6 ml. of ink, per chamber, then seal the filling holes using a piece of tape.
5. Rinse the syringe with water and dry for future use, or use with a different color ink.
6. Reinsert the cartridge(s) and run a test page as per printer instructions.

Note: Immediately refill any empty cartridges.

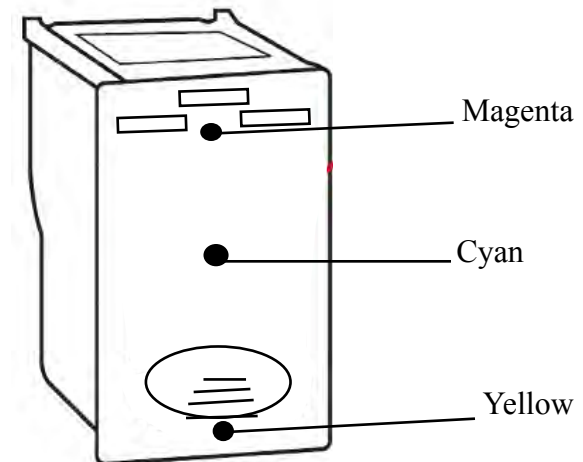
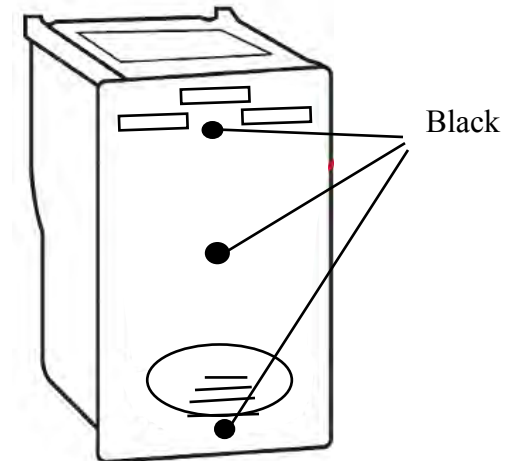

HP 02

Refilling the Black Cartridge:

1. Use the enclosed eyelet screw to create the filling hole at the top of the cartridge. Picture A, on the right, illustrates where the refill hole should be created.
2. Fill the syringe with ink. Insert the needle into the filling hole and push down into the cartridge. Inject up to 20ml of ink or until the cartridge is full. Do not exceed 30ml on these cartridges. It is always better to under fill than over fill any cartridge. You can always add more ink later.
3. Once your cartridge has been filled, remove the needle from the cartridge and plug the top of the cartridge with the plugs provided in your refill kit. Please make sure to seal the plug tight so that no extra air goes in or out of the cartridge as it prints. You will also avoid any spills as well.

Note: OEM (original) black cartridges usually come with only 12ml of ink, so if you're refilling an original it may only hold 12ml. Freeink4life compatible cartridges hold more.

Refilling the Color Cartridges:

1. Use the enclosed eyelet screw to create the filling hole at the top of the cartridge. Picture B, on the right, illustrates where the refill hole should be created.
2. Fill the syringe with ink. Insert the needle into the filling hole and push down into the cartridge. Inject up to 9ml of ink or until the cartridge is full. Do not exceed 9ml on these cartridges. It is always better to under fill than over fill any cartridge. You can always add more ink later.
3. Once your cartridge has been filled, remove the needle from the cartridge and plug the top of the cartridge with the plugs provided in your refill kit. Please make sure to seal the plug tight so that no extra air goes in or out of the cartridge as it prints. You will also avoid any as well.

Note: OEM (original) color cartridges usually come with only about 4ml of ink, so if you're refilling an original it may only hold 4ml. Freeink4life compatible cartridges

NOTE: On OEM HP cartridges, there is a small dimple located near the HP emblem as illustrated on picture B. If this dimple is on your OEM HP cartridges, please create the refilling hole through it. Picture B shows a refilling hole which was created through the dimple of a yellow HP OEM cartridge.

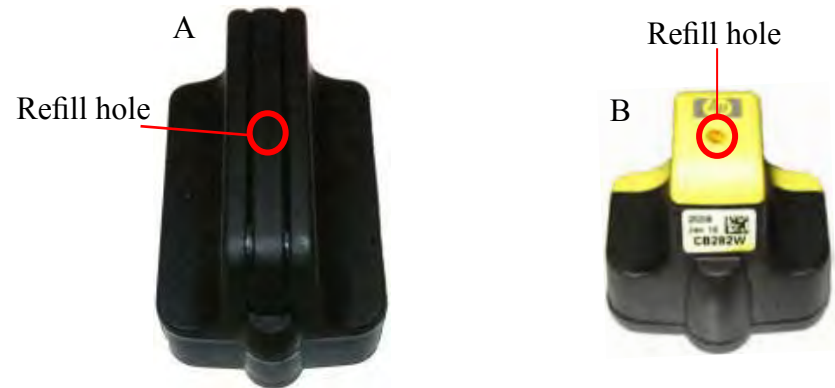

Reinstalling the Cartridges

Reinstalling:

1. Open the lid to your printer.
2. Place your refilled cartridge into the cradle that corresponds with the color of the tank.
3. Close the lid to your printer.
4. A prompt will then display on your printer screen saying "Original HP Ink Depleted".
5. On your printer will be a circle of buttons with "OK" in the middle and arrow keys. Press the right arrow key.
6. A prompt will then display on your printer screen saying "Attention".
7. Press the "OK" button on your printer.

NOTE: The ink levels will not show on the screen. However, once the volume of ink has been depleted from the replaced tank, the printer will not allow you to print any further until the tank has been refilled again.

Note: Some printer models may require chip resetters or replacement chips. Check with your vendor for availability.

Lexmark Cartridges

M = Magenta
Y = Yellow
C = Cyan

Black Cartridges:

**10N0016, 10N0217, 12A1970, 12A1975, 1361400, 13400HC, 1380620,
1382050, 15M2971, 16G0055, 17G0050, 18L0032,**

1. Use the enclosed eyelet screw to enlarge the filling hole located at the top of the cartridge. (Do not remove the cap.)
2. Connect the needle to the syringe and fill the syringe with 8 ml. of Cartridge & Print Head Cleaner and inject into the cartridge. Reinsert cartridge into printer and print 5 test pages.
3. Fill the syringe with ink. Insert the needle into the filling hole and push down into the cartridge. Inject up to 20 ml. of ink or until the cartridge is full.
Note: Immediately refill any empty cartridges.

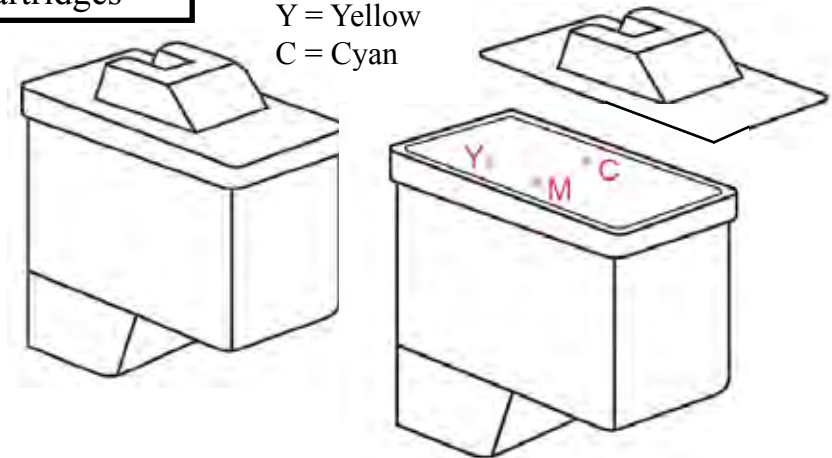

Color Cartridges:

**12A1980, 12A1985, 1380619, 10N0026, 15M0120, 15M0125, 18L0042,
1382060, 17G0060, 16G0065**

**Photo cartridges:
12A1990, 1361760**

1. The filling holes are located under the plastic cap. Use a thin flathead screw driver or knife to remove the cap. Important: Do not to damage the sensors on the back of the cartridge.
2. Connect the needle to the syringe and fill with ink.
3. Insert the needle into the matching hole of the color to be refilled, (see diagram above) and push into the cartridge. Note: You will feel a slight pressure because the cartridge contains a sponge.

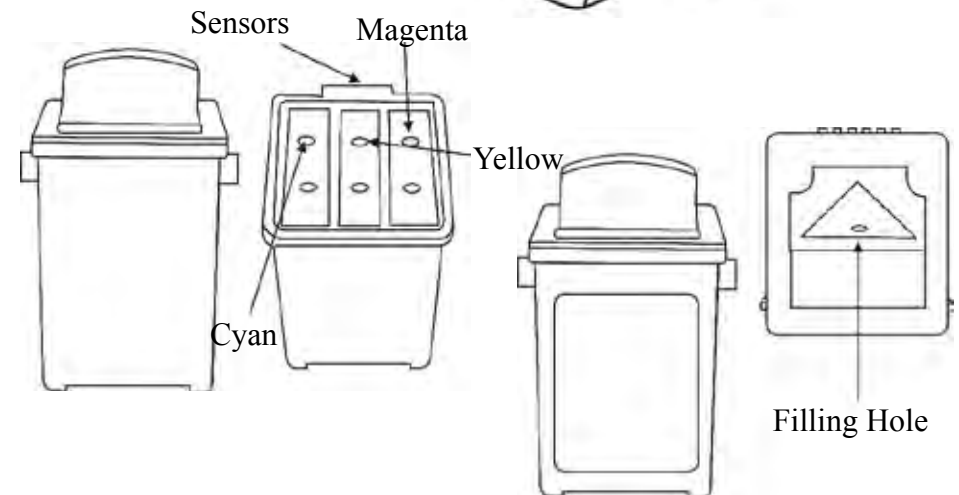

4. Inject about 8 ml. of ink, per color, into the cartridge until the ink begins to bubble at the top of the sponge. Important: Do not overfill. Keep the sponge inside the cartridge white.
5. Rinse the needle and syringe with water and dry between each color refilling or store for future use.
6. The cover can be reattached with a piece of tape.

Lexmark Cartridges

1380490, 1380491, 1380492, 1380493

1. The filling hole is the same hole as the hole that connects to the printer.
2. Note: The cartridge is lined in a delicate Mylar bag and it is very important not to insert the needle more than 3/4" or it is possible to pierce or tear the Mylar bag. Fill the syringe with the correct color ink and carefully insert the needle into the filling hole and slowly inject approximately 90 ml. of ink into the cartridge.
- 3 Hold the cartridge upright with the filling hole at the top. Using the syringe, remove any trapped air in the cartridge by only inserting the tip of the needle and pulling up on the plunger until all air is removed.
4. Remove the syringe and rinse with water and dry for future use, or to use with a different color ink.
5. Reinsert the cartridge and run a priming cycle as per printer instructions.

Note: Immediately refill any empty cartridges.

NOTE: It is not necessary to disassemble the cartridge to refill it and we strongly recommend you do not. We have included a picture of the inside of the cartridge to satisfy your curiosity.

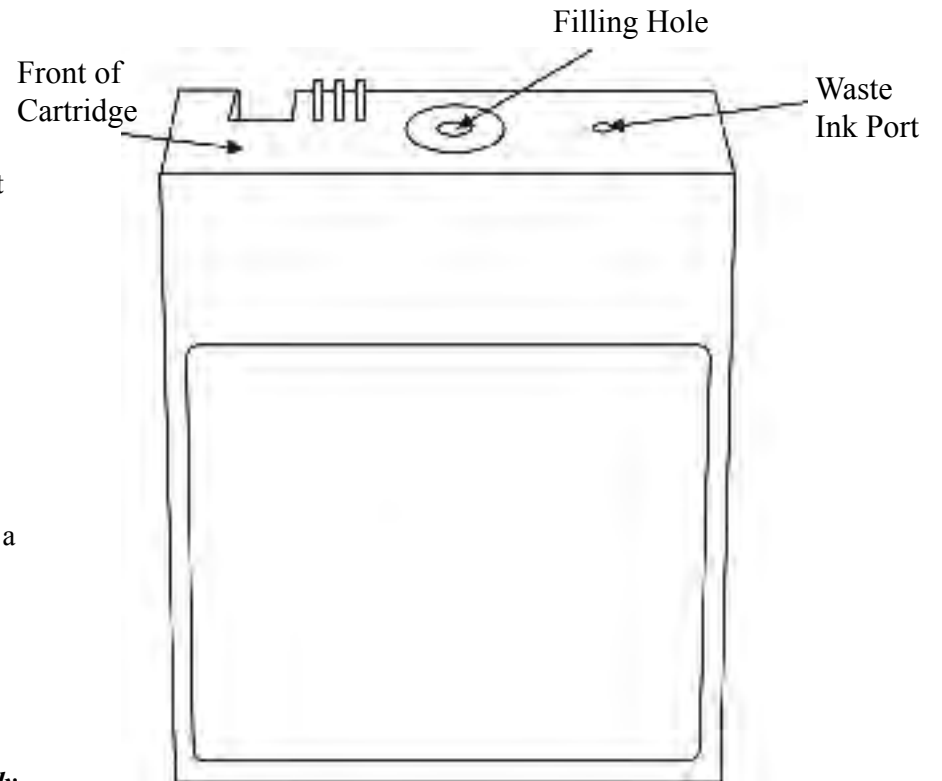

Lexmark Cartridges

**18C0031, 18C0032, 18C0033,
18C0034, 18C0035**

Black Cartridges:

1. Use the enclosed eyelet screw to enlarge the filling hole located at the top of the cartridge. (Do not remove the cap.)
2. Connect the needle to the syringe and fill the syringe with 8 ml. of Cartridge & Print Head Cleaner and inject into the cartridge. Reinsert cartridge into printer and print 5 test pages.
3. Fill the syringe with ink. Insert the needle into the filling hole and push down into the cartridge. Inject up to 20 ml. of ink or until the cartridge is full.
Note: Immediately refill any empty cartridges.

Color Cartridges:

1. The filling holes are located under the plastic cap. Use a thin flathead screw driver or knife to remove the cap. Important: Do not damage the sensors on the back of the cartridge.
2. Connect the needle to the syringe and fill with ink.
3. Insert the needle into the matching hole of the color to be refilled, (see diagram above) and push into the cartridge. Note: You will feel a slight pressure because the cartridge contains a sponge.
4. Inject about 8 ml. of ink, per color, into the cartridge until the ink begins to bubble at the top of the sponge. Important: Do not overfill. Keep the sponge inside the cartridge white.
5. Rinse the needle and syringe with water and dry between each color refilling or store for future use.
6. The cover can be reattached with a piece of tape.

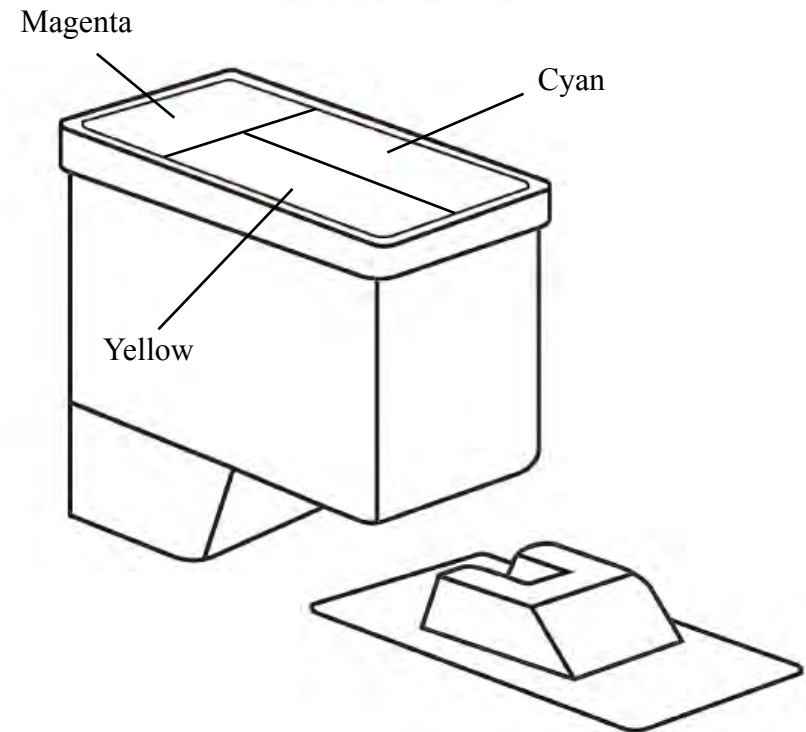
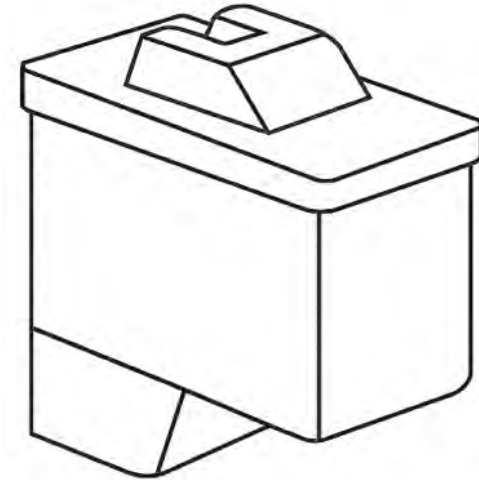

Lexmark Cartridges / Dell Cartridges

Please reference the diagram to the right for your model

1. Peel back the label from the top of the cartridge to expose the refill holes of the cartridge. *(If the illustration on the right differ from your cartridge model, use 3 toothpicks and poke each hole to determine its color)*
2. Fill the syringe with 15ml of black ink (5ml for each color on color cartridges).
3. Insert the needle into the cartridge (corresponding with the correct color ink) and fill. If too much ink is inserted, pull back on the syringe handle to pull 1ml out.

***IMPORTANT:** When refilling, only puncture the top of the sponge in the cartridge, about 1/8 to 1/4 inch. Puncturing to the bottom may cause leakage in the cartridge.*

4. Stick the label back in place, if the label has been destroyed, use duct tape or electrical tape. *(Try keeping the label size when using tape)*
5. Rinse the syringe with water and dry between each color refill or store for future use.
6. Reinstall the cartridge and run 1 - 3 test pages as per printer instructions. If necessary leave the cartridge in printer for up to 24 hours to allow ink to flow to the print head.

NOTE: Cartridges that are not refilled right away may and can dry with time. For the best results, refill right after the cartridges are depleted.

DELL
MK990, MK992,
Series 7, Series 8, Series 9, Series 15,
Series 11

LEXMARK
#3, #4A, #14A, #23A, #28A, #32,
#34, #36A, #42A, #44

DELL
MK991, MK993,
Series 7, Series 8, Series 9, Series 15,
Series 11

LEXMARK
#1, #2, #5A, #15A, #24A, #29A,
#33, #35, #37A, #41A, #43



NOTE: If your cartridge is part of Lexmark's recycle program, then the refilling holes might not be viewable. In this case you can drill a hole in the same area's indicated above to refill the cartridge.

Lexmark Cartridges / Dell Cartridges

Items needed: gloves, hand-drill, cartridges, paper towels.

Note: You will need the Lexmark 100A version.

Lexmark offers for sale two different versions of the same cartridge: The regular version (#100) is not refillable. It is the “Return Program” or “Prebate” cartridge. Supposedly, when you buy this cartridge you agree to return the empty cartridge to Lexmark. In return, Lexmark gives you roughly \$5 off the retail list price of the cartridge. The “A” version (#100A) can easily be refilled. However, the price of the cartridge is roughly \$5 higher than the regular version, so most people unknowingly buy the regular version. If you want to refill, you will need “A” version cartridges.

1. Put the cartridge on some paper towels in an area where you can tolerate a spill.
2. Fill the syringe with 12ml. of black ink or 5 ml of Color Ink .
3. Pierce with the needle into the label where black meets white. (you can rub your finger over the label and feel the hole underneath.) See illustration.
4. Push the needle at least half way down into the sponge and Very S-L-O-W-L-Y inject ink into the sponge.
5. When finished, leave the pierced hole open (this will just be a vent hole).
6. Replace the cartridge and run 1 - 3 cleaning cycles as per printer instructions.

Or print the following pages:

http://www.freeink4life.com/black_print_test.html Black ink test

http://www.freeink4life.com/support/color_print_test.html Color ink Test

For best results, leave cartridge in printer for 8 hours after refilling so the ink can saturate the entire sponge.

LEXMARK 100A



Pierce needle here



Pierce needle here

Okidata Cartridges

**Black Cartridge:
52109301**

1. Use the enclosed eyelet screw to enlarge the filling hole located at the top of the cartridge. (Do not remove the cap.)
2. Connect the needle to the syringe and fill the syringe with 8 ml. of Cartridge & Print Head Cleaner and inject into the cartridge. Reinsert cartridge into printer and print 5 test pages.
- 3 Fill the syringe with ink. Insert the needle into the filling hole and push down into the cartridge. Inject up to 20 ml. of ink or until the cartridge is full.
Note: Immediately refill any empty cartridges.

**Color Cartridge:
52109302**

1. The filling holes are located under the plastic cap. Use a thin flathead screw driver or knife to remove the cap. *Important: Do not to damage the sensors on the back of the cartridge.*
2. Connect the needle to the syringe and fill with ink.
3. Insert the needle into the matching hole of the color to be refilled, (see diagram above) and push into the cartridge. *Note: You will feel a slight pressure because the cartridge contains a sponge.*
4. Inject about 8 ml. of ink, per color, into the cartridge until the ink begins to bubble at the top of the sponge. *Important: Do not overfill. Keep the sponge inside the cartridge white.*
5. Rinse the needle and syringe with water and dry between each color refilling or store for future use.
6. The cover can be reattached with a piece of tape.

Fill Holes

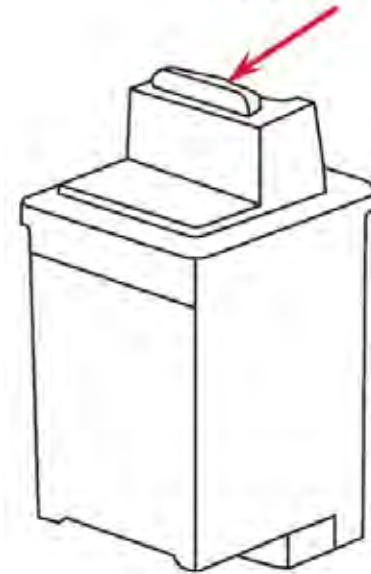

Cyan Yellow Magenta

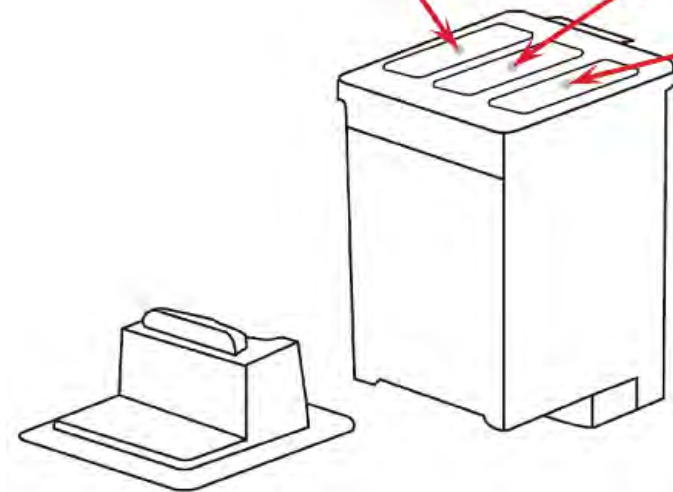

Okidata Cartridges

52110001, 52110002, 52110003, 52110004

1. The filling hole is located under the label as shown. Just peel back the label leaving it still connected to the cartridge, do not remove completely.
2. Use the provided eyelet screw to drill a filling hole on the top of the cartridge(s) opposite side of the sponge.
3. Connect the needle to the syringe and fill with ink.
4. Insert the needle into the filling hole and inject about 5ml of ink.
5. Use the provided plug to seal the hole. **Note: If the cartridge has been empty/dry, the sponge will no longer accept any ink which will cause the cartridge to leak.** Pull the label back into place and use a piece of tape to hold it in place.
6. Rinse the syringe with water and dry between each color refill or store for future use.
7. Reinsert cartridge back into the printer and run 1 - 3 cleaning cycles as per printer instructions.

Note: Immediately refill any empty cartridges

Filling hole

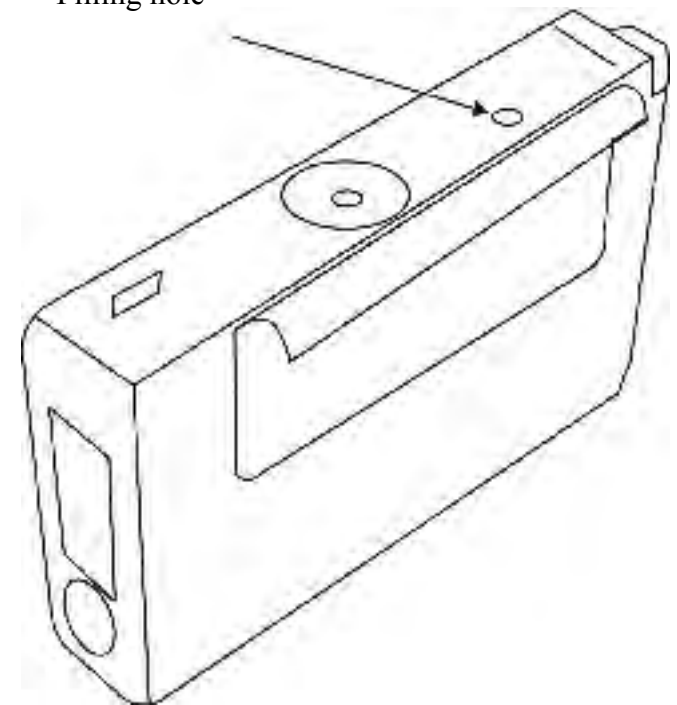

Pitney Bowes Cartridge

769-0

1. Put a piece of tape over the exit hole located on the bottom of the cartridge
2. The filling hole is located on the back of the cartridge and must be widen using the included eyelet screw
3. Connect the needle to the syringe and fill with FLOUROESCENT RED ink.
4. Insert the syringe into the filling hole all the way down into the cartridge.
Note: This cartridge contains a sponge so you may feel a slight pressur.
6. Use your thumb to hold the tape in place while injecting 4 ml. of ink into the cartridge.
7. Rinse the syringe with water and dry for future use.
8. Reinsert the cartridge(s) and run a cleaning cycle as per postage machines instructions.

Note: Immediately refill any empty cartridges.

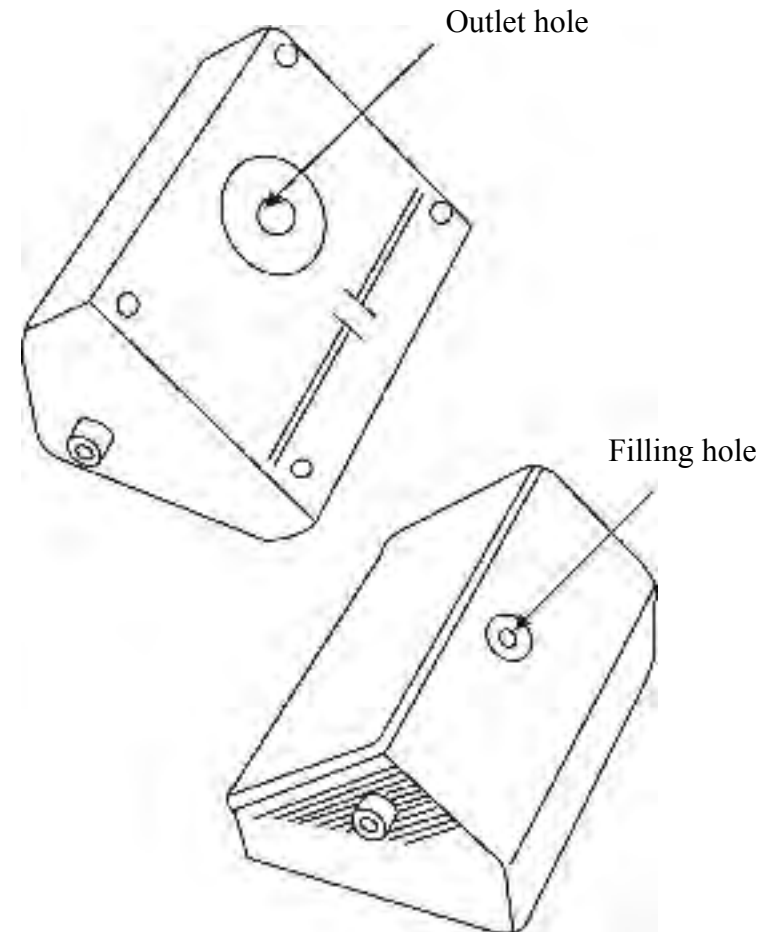

Sharp Cartridges

**Black Cartridges:
AJ-C50B, UX-C70B**

1. Use the enclosed eyelet screw to enlarge the filling hole located at the top of the cartridge. (Do not remove the cap.)
2. Connect the needle to the syringe and fill the syringe with 8 ml. of Cartridge & Print Head Cleaner and inject into the cartridge. Reinsert cartridge into printer and print 5 test pages.
3. Fill the syringe with ink. Insert the needle into the filling hole and push down into the cartridge. Inject up to 20 ml. of ink or until the cartridge is full.
Note: Immediately refill any empty cartridges

**Color Cartridge:
AJ-C50C**

1. The filling holes are located under the plastic cap. Use a thin flathead screw driver or knife to remove the cap. **Important: Do not to damage the sensors on the back of the cartridge.**
2. Connect the needle to the syringe and fill with ink.
3. Insert the needle into the matching hole of the color to be refilled, (see diagram above) and push into the cartridge. **Note: You will feel a slight pressure because the cartridge contains a sponge.**
4. Inject about 8 ml. of ink, per color, into the cartridge until the ink begins to bubble at the top of the sponge. **Important: Do not overfill. Keep the sponge inside the cartridge white.**
5. Rinse the needle and syringe with water and dry between each color refilling or store for future use.

6. The cover can be reattached with a piece of tape.

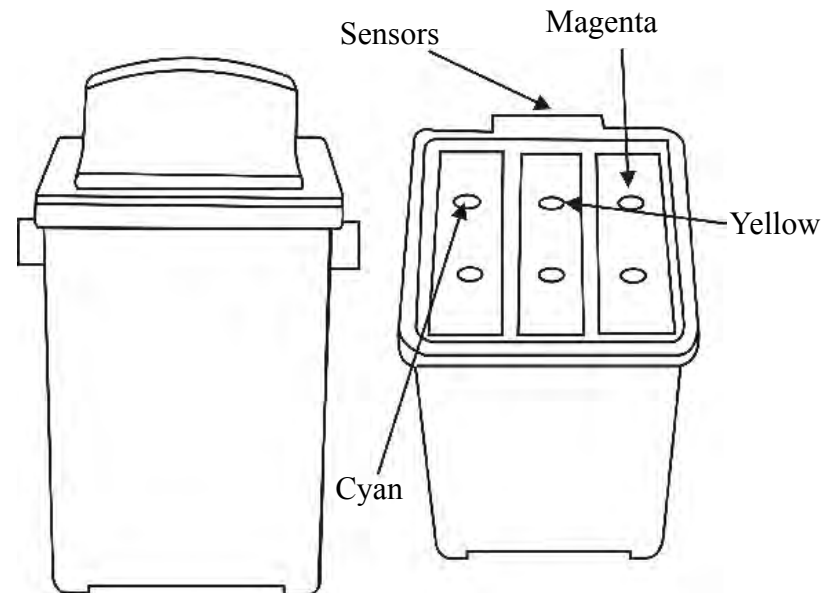
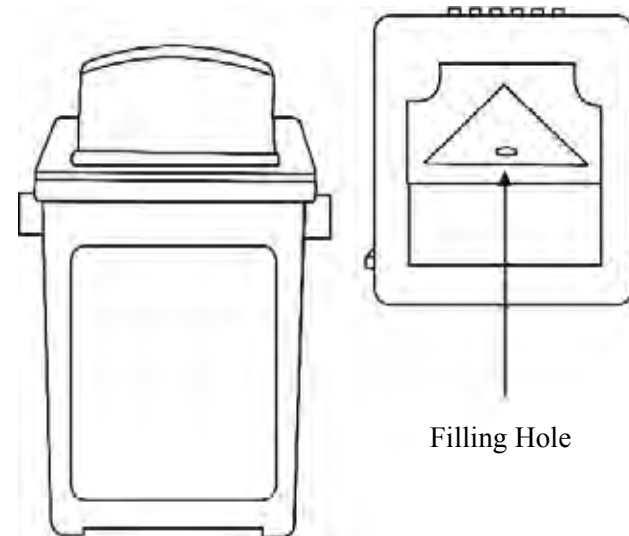

Xerox Cartridges

Note: Immediately refill any empty cartridges.

Color Cartridges: 8R12591, 8R7880, 8R882

1. The filling holes are located under the plastic cap. Use a thin flathead screw\ driver or knife to remove the cap. **Important: Do not to damage the sensors on the back of the cartridge.**
2. Connect the needle to the syringe and fill with ink.
3. Insert the needle into the matching hole of the color to be refilled, (see diagram above) and push into the cartridge. **Note: You will feel a slight pressure be cause the cartridge contains a sponge.**
4. Inject about 8 ml. of ink, per color, into the cartridge until the ink begins to bubble at the top of the sponge. **Important: Do not overfill. Keep the sponge inside the cartridge white.**
5. Rinse the needle and syringe with water and dry between each color refilling or store for future use.
6. The cover can be reattached with a piece of tape

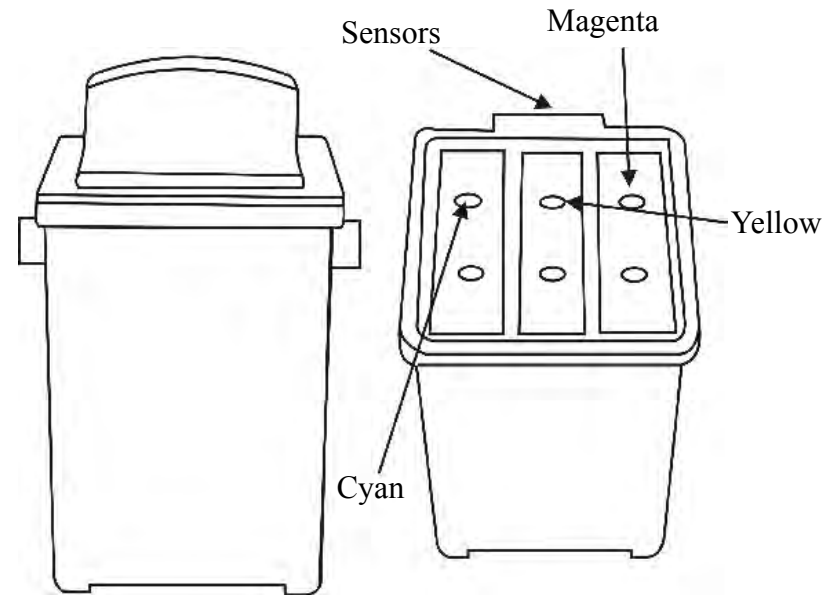

Black Cartridges: 8R7881

1. Use the enclosed eyelet screw to enlarge the filling hole located at the top of the cartridge. (Do not remove the cap.)
2. Connect the needle to the syringe and fill the syringe with 8 ml. of Cartridge & Print Head Cleaner and inject into the cartridge. Reinsert cartridge into printer and print 5 test pages.
- 3 Fill the syringe with ink. Insert the needle into the filling hole and push down into the cartridge. Inject up to 20 ml. of ink or until the cartridge is full.

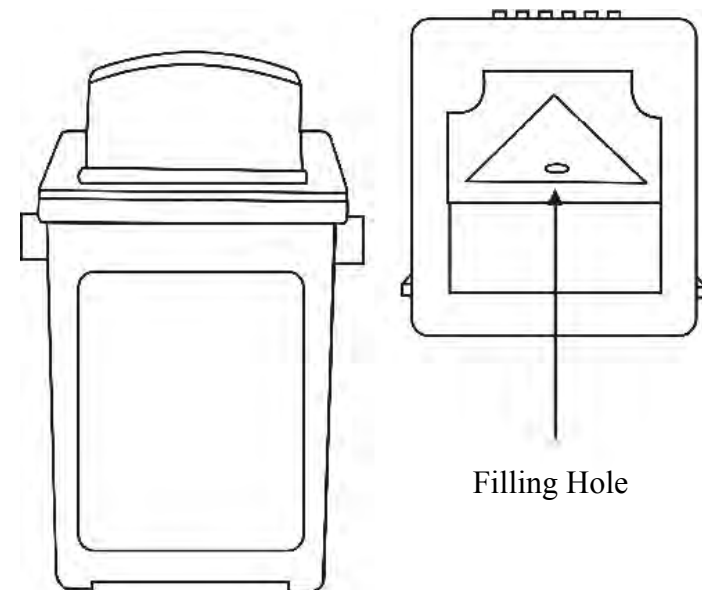

Xerox Cartridges

8R7660, 8R7661, 8R7662, 8R7663

1. The filling hole is located under the label as shown. Just peel back the label leaving it still connected to the cartridge, do not remove completely.
2. Use the provided eyelet screw to drill a filling hole on the top of the cartridge(s) opposite side of the sponge.
3. Connect the needle to the syringe and fill with ink.
4. Insert the needle into the filling hole and inject about 5ml of ink.
5. Use the provided plug to seal the hole. **Note: If the cartridge has been empty/dry, the sponge will no longer accept any ink which will cause the cartridge to leak.**
Pull the label back into place and use a piece of tape to hold it in place.
6. Rinse the syringe with water and dry between each color refill or store for future use.
7. Reinsert cartridge back into the printer and run 1 - 3 cleaning cycles as per printer instructions.

Note: Immediately refill any empty cartridges

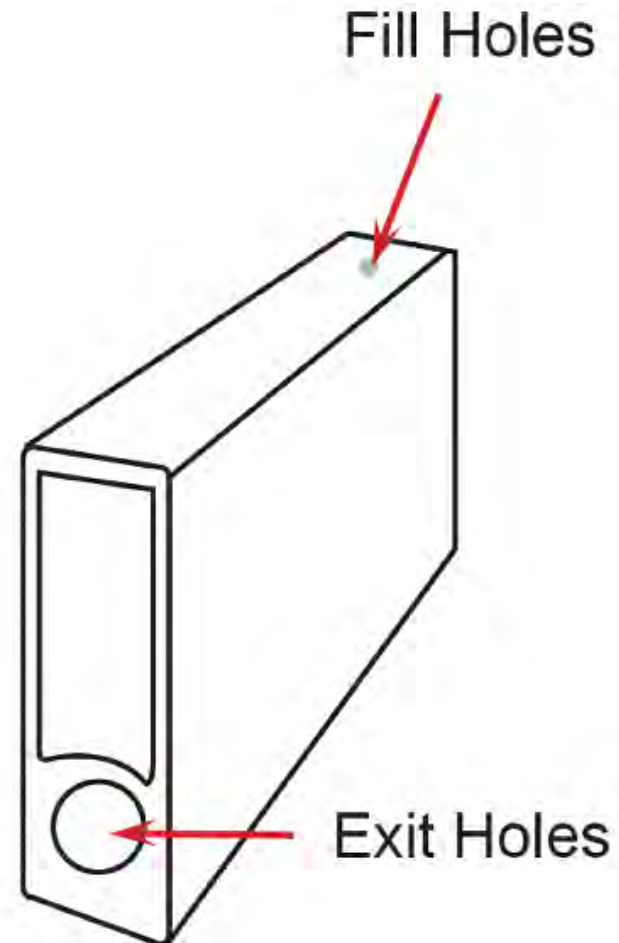

Xerox Cartridges

8R7638

1. Using the included hole making tool make a filling hole in the front of the cartridge about 1/2" from the top.
2. Connect the needle to the syringe and fill with ink.
3. Insert the filling needle into the hole and aim it towards the center of the cartridge.

Note: The cartridge contains a dense sponge made out of felt. As soon as the needle touches the felt stop pushing in the needle.

4. Inject up to 40 ml. of ink or until ink bubbles at the filling hole.
5. Use either the plug included in the kit or a piece of tape to seal the filling hole.
6. Rinse the syringe and needle with water and dry for future use.
7. Reinsert the cartridge and run a priming cycle as per printer instructions.

Note: Empty cartridges should be refilled immediately.

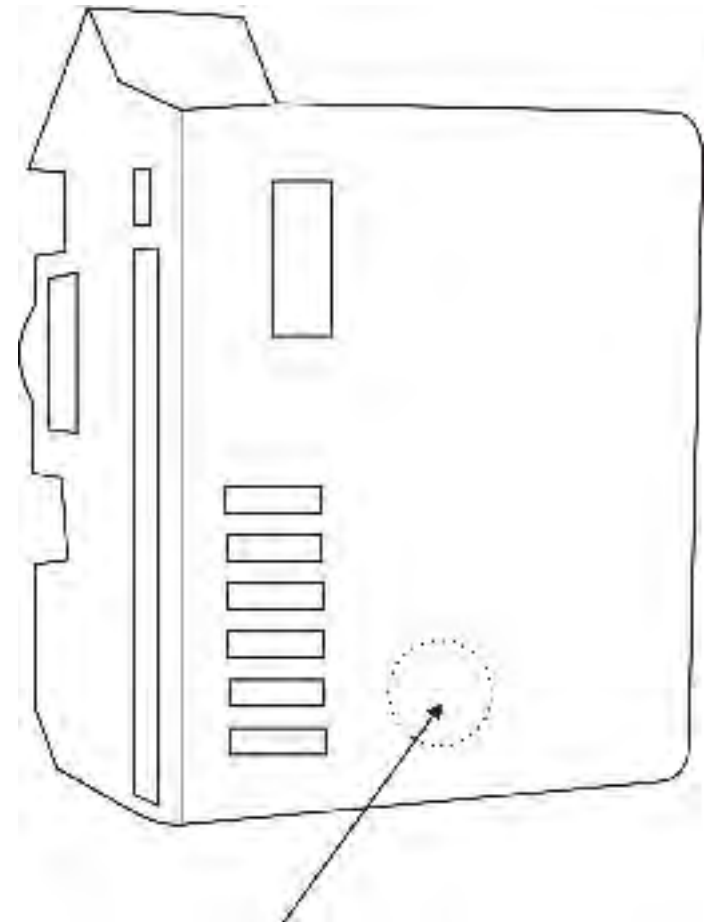

Make 1/8" /3mm
filling hole

Xerox Cartridges

8R7903, 8R7904

1. The filling holes are located under the plastic cap. The cap is held in place with a pin at the each corner. Use a thin flathead screwdriver or knife to remove the cap. **Important: Do not to damage the sensors on the back of the cartridge.**
2. Connect the needle to the syringe and fill with ink.
3. Insert the needle into the matching hole of the color to be refilled, (see diagram above) and push into the cartridge. **Note: You will feel a slight pressure because the cartridge contains a sponge.**
4. Inject about 10 ml. of ink, per color, into the cartridge until the ink begins to bubble at the top of the sponge. **Important: Do not overfill. Keep the sponge inside the cartridge white.**
5. Rinse the needle and syringe with water and dry between each color refilling or store for future use.
6. The cover can be put back onto the cartridge by pressing it down.

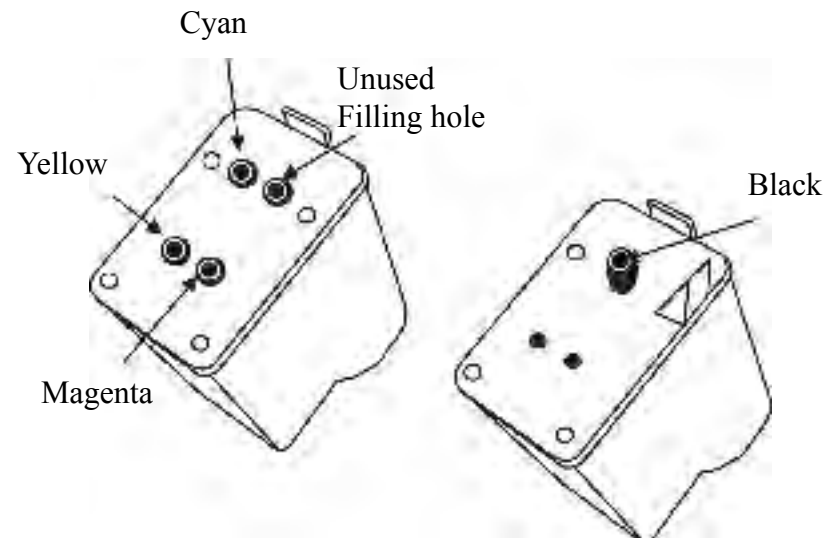
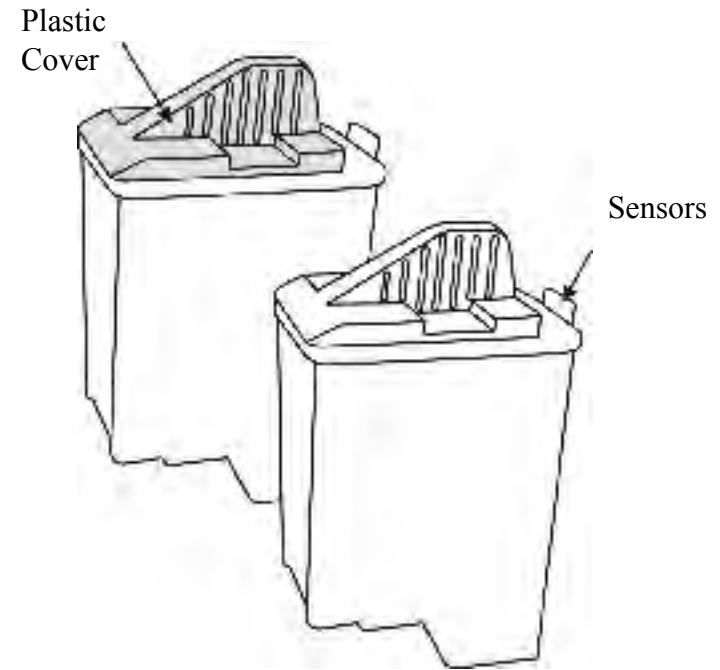

Xerox Cartridges

8R12728

1. Use the eyelet screw to make the filling hole in the small notch on the corner located next to the “1” shown on the label.
2. Fill the syringe with ink and inject about 8 ml. of ink until the ink tank is full.
3. Use a piece of tape to seal the filling hole, make sure that the tape is stuck to the cartridge.
4. Rinse the syringe with water and dry for future use, or use with a different color ink.
5. Reinsert the cartridge and run a priming cycle as per printer instructions.

Note: Immediately refill any empty cartridges.

Top and body of cartridge

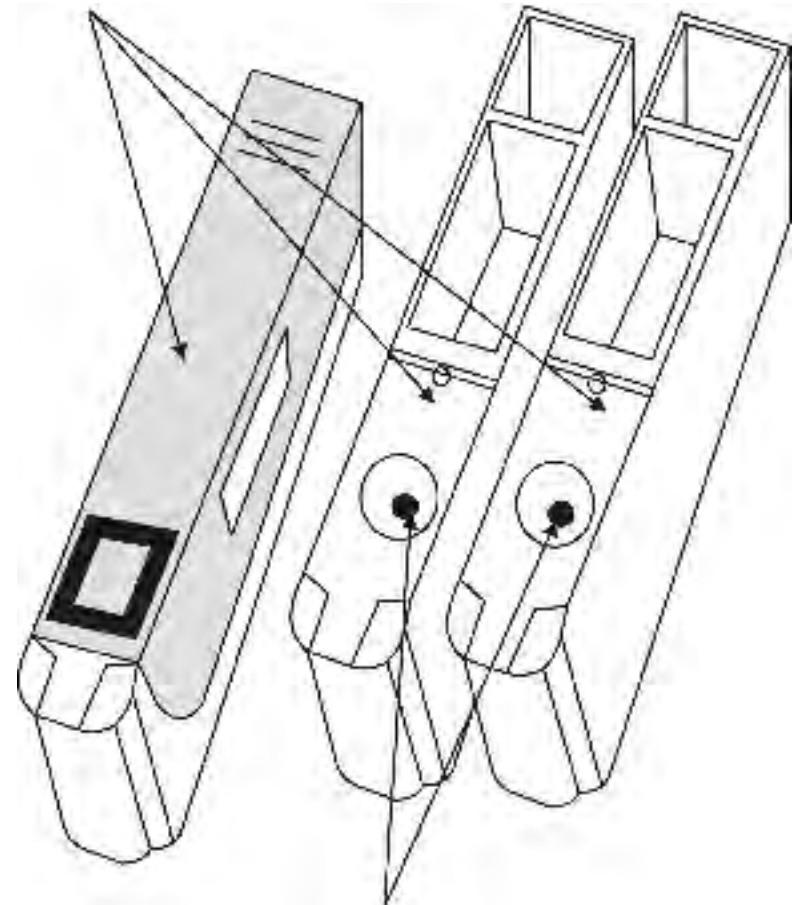

Filling Hole Under Label

Xerox Cartridges

8R7971, 8R7972, 8R7973, 8R7974

1. The filling hole is located under the label on the top of the cartridge. Use the empty needle to pierce through the label to make the filling hole.
2. Fill the syringe with ink and inject about 4 ml. of ink until the ink tank is full.
3. Use a piece of tape to seal the filling hole, make sure that the tape is stuck to the cartridge
4. Rinse the syringe with water and dry for future use, or use with a different color ink.
5. Reinsert the cartridge and run a priming cycle as per printer instructions.

Note: Immediately refill any empty cartridges.

Top and body of cartridge

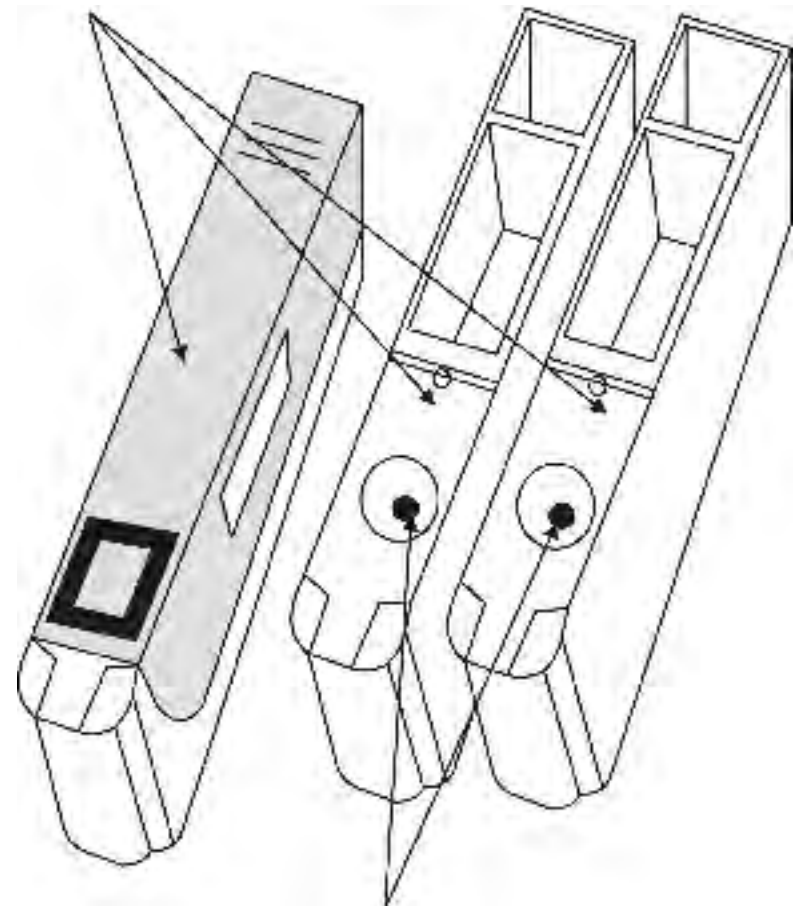

Filling Hole Under Label

Pitney Bowes793-5

- 1) Peel off the sticker on the top front of the cartridge (original Pitney Bowes cartridges have a sticker that covers the entire top side of the cartridge, whereas NuPost Compatible cartridges have a smaller sticker)
- 2) Underneath the sticker, you will notice at least 1 hole. Locate the hole that is covered by a silver foil seal tab, this silver seal covers the filling hole. (If you do not see this hole in your cartridge, please use the illustration to your right to create a hole to refill the cartridge).
- 3) Attach the needle to the syringe and draw up 8ml of compatible ink.
- 4) Either insert the needle through the silver seal, or remove the seal first using a small knife or blade and then insert the needle through the filling hole. (do NOT insert the needle through any hole that has a rubber protrusion, as indicated by the lower hole in this NuPost compatible cartridge). The filling hole should provide no initial resistance to your needle other than the seal that lies above it. Once you insert the needle into the cartridge, you will begin to feel some resistance due to the sponge inside the cartridge, it is OK to penetrate this sponge. Push the needle gently through to the bottom of the sponge, and inject about 8cc (8ml) of ink or until the cartridge is full. You will know the cartridge is full because the sponge will no longer be able to hold any more ink.
- 5) Seal the filling hole with electrical tape, and allow the cartridge to sit for a few minutes over some paper towels in order to allow the ink to settle to the bottom of the cartridge, and for any overflow to drip and settle its way out through the bottom. Once the cartridge is no longer dripping, you can place it back in the printer.



Create refill hole here



- 1) SKIP THIS STEP if your cartridge is not a Pitney Bowes original cartridge. The original PB cartridges have a cap which needs to be removed. Using a medium sized flat screwdriver, lift the tab as shown in the picture. Once the tab has cleared the top of the cartridge, slide the cap away from you until it is completely removed from the cartridge.

OEM



- 2) Remove the circular silver seal tabs (not necessary for Nupost compatible cartridges). Pay careful attention to both areas exposed by removing the silver seals, you will notice that 1 are actually has 2 holes right next to each other, whereas the other area only has 1 hole. In the area that has 2 holes next to each other, make sure NOT to put ink into the outer hole, as that is a vent hole and any ink poured in there will leak out the bottom of the cartridge.



- 3) FOR PITNEY BOWES ORIGINAL CARTRIDGES: Enlarge the 2 filling holes (the one on the right of the picture shown, and the INNER of the 2 holes on the left of the cartridge as shown). You can enlarge these holes using an eyelet screw or a small drill bit. Note that you need to fill BOTH filling holes with ink in order for the cartridge to work.

FOR NUPOST COMPATIBLE CARTRIDGES: There are 2 filling holes, the one is a self-sealing rubber hole in the middle of the circle on the left, and the other is to the right of the picture which needs to be enlarged with an eyelet screw or small drill. Both these holes (the larger self sealing hole on the left, as well as the hole you have enlarged on the right) need to be filled with ink.

Compatible



- 4) Draw up compatible ink in the syringe, and fill both chambers as positioned in point 4 above. The larger chamber on the left will hold more ink. Do NOT overfill the chambers, especially the right chamber. If you have filled it to the brink, carefully remove a small amount of ink to avoid it spilling. You will know when each chamber is full because you will see the ink coming to the top. Stop short of the top for both chambers to avoid spillage.

- 5) Cover both filling holes with electrical tape, making sure to leave the middle vent hole open on the Nupost model as shown below.

- 6) Replace the cap of the cartridge (not needed for Nupost model). If the cartridge is dripping ink, place it on some paper towels until it has pressurized and stopped dripping. Now you can place it back in the Pitney Bowes meter.

- 1) Locate the filling hole in the center of the rubber plug as shown in the image below. For Nupost models, this filling hole is covered by a silver seal. You can poke through the silver seal with the syringe and needle.
- 2) Inject approximately 25ml into the cartridge, being careful not to overfill.
- 3) Place the cartridge back into the mailing machine and run a test cycle. Prompt your machine to let it know that you have inserted a new cartridge.

